

# MODEL DDV DIAPHRAGM DELUGE VALVE

Electric Actuation, Wet Pilot, Dry Pilot,  
and Dry Pilot Pressure Regulating Trims

## PRODUCT DESCRIPTION

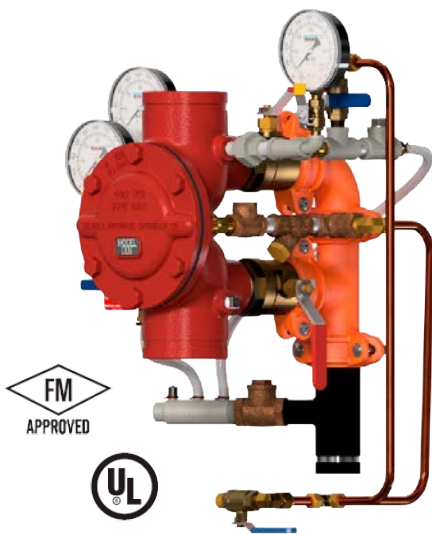

The Model DDV deluge valve is an FM Approved and UL listed diaphragm-type deluge valve available in 1-1/2" (40mm), 2" (50mm), 2-1/2" (65mm), 76mm, 3" (80mm), 4" (100mm), 6" (150mm), and 165mm nominal sizes with multiple end configurations (see Table A).

The valve's diaphragm seals against a seat machined in the valve body. Water pressure in the chamber between the diaphragm and the cover presses the diaphragm against the seat to prevent water flow through the valve. The release of water pressure from the chamber allows the diaphragm to deform away from the seat, which permits water to flow through the valve.

Maintenance of the valve is simplified because all trim is connected to the valve body, and the diaphragm can be removed without removing the trim.

Three release trim packages are available: electric actuation, wet pilot line, and dry pilot line. The dry pilot line trim can also be ordered with a pressure regulating option to regulate the water pressure downstream of the valve. Water supply input pressures up to 400 psi (27.6 bar) can be regulated by the Model DDV valve to an output pressure of 20 to 200 psi (1.4 to 13.8 bar) for 6" (150mm) and 165mm sizes, and 50 to 200 psi (3.4 to 13.8 bar) for all other sizes.

All trim options include 0-300 psi water pressure Gauges for the incoming water supply and control chamber; in addition, the dry pilot pressure regulating trim includes a 0-300 psi water pressure gauge for adjusting the outlet pressure.

Optional 0-600 pressure gauges are available. 2-1/2" and larger Model DDV systems with groove end connections may be ordered with or without control valves (water supply valve and upper service valve), and an optional spool piece with an outlet for the control chamber supply is also available.

Control valves will be Reliable REL-BFG-300 grooved end butterfly valves with integral tamper switches. Plugged outlets are provided for alarm devices that are ordered separately.

For convenience, an optional alarm line test valve kit may be installed (see Figure 10).

REF: VDRDDV\_032021\_REVO

### AQL PROTECCION

Carretera N-340 Km 1245, 3 Nave B-5 Polígono industrial El Pla 08750 Molins de Rei, Barcelona (España)  
Tel. (+34) 936800376 \* WhatsApp pedidos: 660781482 \* [www.aqlproteccion.com](http://www.aqlproteccion.com) \* [aql@aqlproteccion.com](mailto:aql@aqlproteccion.com)

### ANBER

Avda. de las Flores, 13-15 P.E. El Molino 28970 Humanes de Madrid, Madrid (España)  
Tel. (+34) 916063711 \* WhatsApp pedidos: 649787619 \* [www.anber.es](http://www.anber.es) \* [anber@anber.es](mailto:anber@anber.es)

## PRODUCT FEATURES

- Compact trim with all connections to the valve body.
- Valve can be reset without removing cover.
- Suitable for horizontal or vertical installation.
- Pressure regulating dry pilot version allows up to 27.6 bar (400psi) inlet pressure.

**TABLE A: End Configuration Options**

GR x GR (ANSI/ AWWA C606)	Class 150 FLG x FLG (ASME B16.5)	Class 300 FLG x FLG (ASME B16.5)	PN16 FLG x FLG (ISO 7005-2)	BS-E FLG x FLG (BS 10)	NPT THD x THD (ANSI/AMSE B1.20.1)	ISO 7/1 THD x THD
All Sizes	All Sizes (exc. 76 & 165mm)	All Sizes (exc. 76 & 165mm)	All Sizes (exc. 76 & 165mm)	All Sizes (exc. 76 & 165mm)	1-1/2", 2", 2-1/2", & 3" (40, 50, 65, & 80mm)	1-1/2", 2", 2-1/2", & 3" (40, 50, 65, & 80mm)

**TABLE B: Technical Data**

Valve Size	Trim	Maximum Flow gpm L/min	Rated Pressure bar (psi)	Valve Output Range bar (psi)	Approvals
1-1/2" (40mm)	Electric Actuation (12 bar)	NA	12,0 (175)	NA	FM UL
	Electric Actuation (20,7 bar)	NA	20,7 (300)	NA	
	Wet Pilot	NA	27,6 (400)	NA	
	Dry Pilot	NA	27,6 (400)	NA	
	Dry Pilot Pressure Regulating	1023	27,6 (400)	3,4 - 13,8 (50 - 200)	
2" (50mm)	Electric Actuation (12 bar)	NA	12,0 (175)	NA	
	Electric Actuation (20,7 bar)	NA	20,7 (300)	NA	
	Wet Pilot	NA	27,6 (400)	NA	
	Dry Pilot	NA	27,6 (400)	NA	
	Dry Pilot Pressure Regulating	1137	27,6 (400)	3,4 - 13,8 (50 - 200)	
2 1/2"(65mm)	Electric Actuation (12 bar)	NA	12,0 (175)	NA	
	Electric Actuation (20,7 bar)	NA	20,7 (300)	NA	
	Wet Pilot	NA	27,6 (400)	NA	
	Dry Pilot	NA	27,6 (400)	NA	
	Dry Pilot Pressure Regulating	1514	27,6 (400)	3,4 - 13,8 (50 - 200)	
76mm 3" (80mm)	Electric Actuation (12 bar)	NA	12,0 (175)	NA	
	Electric Actuation (20,7 bar)	NA	20,7 (300)	NA	
	Wet Pilot	NA	27,6 (400)	NA	
	Dry Pilot	NA	27,6 (400)	NA	
	Dry Pilot Pressure Regulating	5072	27,6 (400)	3,4 - 13,8 (50 - 200)	
4" (100mm)	Electric Actuation (12 bar)	NA	12,0 (175)	NA	
	Electric Actuation (20,7 bar)	NA	20,7 (300)	NA	
	Wet Pilot	NA	27,6 (400)	NA	
	Dry Pilot	NA	27,6 (400)	NA	
	Dry Pilot Pressure Regulating	1023	27,6 (400)	3,4 - 13,8 (50 - 200)	
6" (150mm) 165mm	Electric Actuation (12 bar)	NA	12,0 (175)	NA	
	Electric Actuation (20,7 bar)	NA	20,7 (300)	NA	
	Wet Pilot	NA	27,6 (400)	NA	
	Dry Pilot	NA	27,6 (400)	NA	
	Dry Pilot Pressure Regulating	11350	27,6 (400)	1,4 - 13,8 (20 - 200)	

REF: VDRDDV\_032021\_REV0

### AQL PROTECCION

Carretera N-340 Km 1245, 3 Nave B-5 Polígono industrial El Pla 08750 Molins de Rei, Barcelona (España)  
Tel. (+34) 936800376 \* WhatsApp pedidos: 660781482 \* [www.aqlproteccion.com](http://www.aqlproteccion.com) \* [aql@aqlproteccion.com](mailto:aql@aqlproteccion.com)

### ANBER

Avda. de las Flores, 13-15 P.E. El Molino 28970 Humanes de Madrid, Madrid (España)  
Tel. (+34) 916063711 \* WhatsApp pedidos: 649787619 \* [www.anber.es](http://www.anber.es) \* [anber@anber.es](mailto:anber@anber.es)

**Notes for Pressure Regulating Trim:**

1. For supply pressures up to 20,7 bar (300 psi), a maximum regulated outlet pressure across the full Valve Output Range can be maintained within +/- 10% for inlet pressures that are at least 2,4 bar (35 psi) greater than the outlet pressure where the nominal water velocity is up to 1000 feet per minute (5m/s).
2. For supply pressures more than 20.7 bar (300 psi) and up to 27,6 bar (400 psi), a maximum regulated outlet pressure of 6,7 to 13,8 bar (100 to 200 psi) can be maintained within +/- 10% for inlet pressures that are at least 3,4 bar (50 psi) greater than the outlet pressure where the nominal water velocity is up to 1000 feet per minute (5 m/s).

**FIGURE 1. Drain Trim Options**

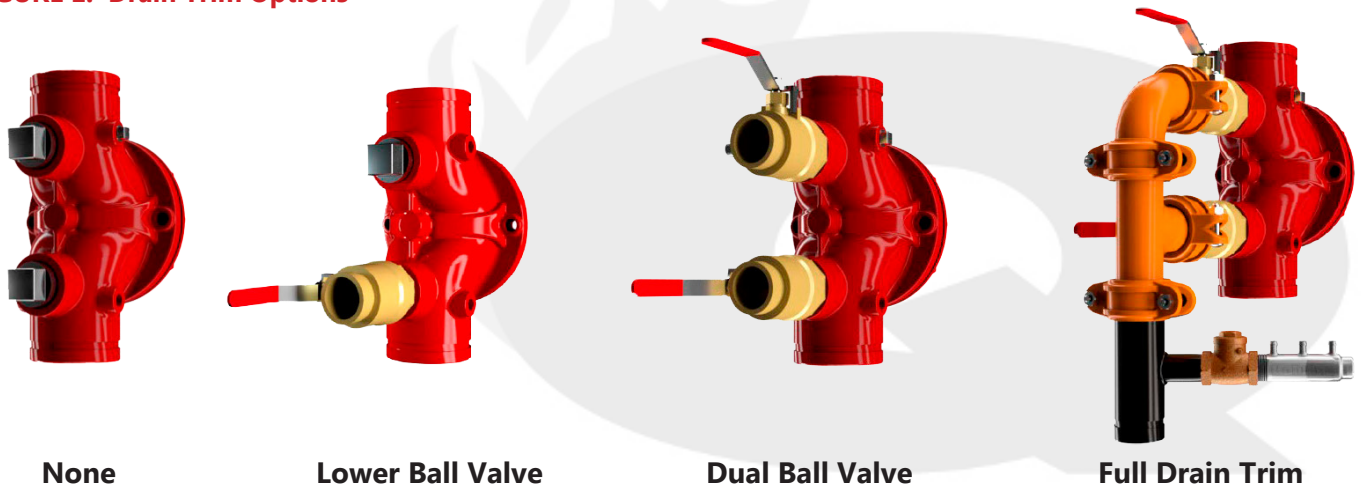

**Note:** 2" grooved version shown; 1-1/4" drain (2-1/2", 76mm, and 3" valves) and 1" drain (1-1/2" and 2" valves) will be threaded.

**Model DDV Deluge Valve with Electric Actuation Trim**



■ **Technical Specifications**

Pressure Rating:  
 Standard: 12,7 bar (175 psi).  
 Optional: 20,7 bar (300 psi).

■ **Approvals**

FM Approved.  
 UL Listed.

■ **Material Specifications**

Body & Cover: Ductile Iron with Red Oxide Epoxy coating and Urethane external coating.  
Diaphragm: Fabric-reinforced EPDM.

■ **Actuator**

Standard: Parker Hannifin 24 VDC Normally Closed Solenoid Valve Model 73218BNUNLVNOC111C2 10 Watt, 0.41 Amp Holding - 12,7 bar (175 psi).  
Optional: Parker Hannifin 24 VDC Normally Closed Solenoid Valve Model 73212BN4TNLVNOC322C2 22 Watt, 0.92 Amp Holding - 20,7 bar (300 psi).

■ **End Connections**

See Table A, page 2.

■ **Installation Orientation**

Vertical.  
 Horizontal.

■ **Drain Trim Options**

See Figure 1, page 3.

REF: VDRDDV\_032021\_REV0

AQL PROTECCION  
 Carretera N-340 Km 1245, 3 Nave B-5 Polígono industrial El Pla 08750 Molins de Rei, Barcelona (España)  
 Tel. (+34) 936800376 \* WhatsApp pedidos: 660781482 \* [www.aqlproteccion.com](http://www.aqlproteccion.com) \* [aql@aqlproteccion.com](mailto:aql@aqlproteccion.com)

ANBER  
 Avda. de las Flores, 13-15 P.E. El Molino 28970 Humanes de Madrid, Madrid (España)  
 Tel. (+34) 916063711 \* WhatsApp pedidos: 649787619 \* [www.anber.es](http://www.anber.es) \* [anber@anber.es](mailto:anber@anber.es)

**FIGURE 2. Model DDV Deluge Valve with Electric Actuation Dimensions**

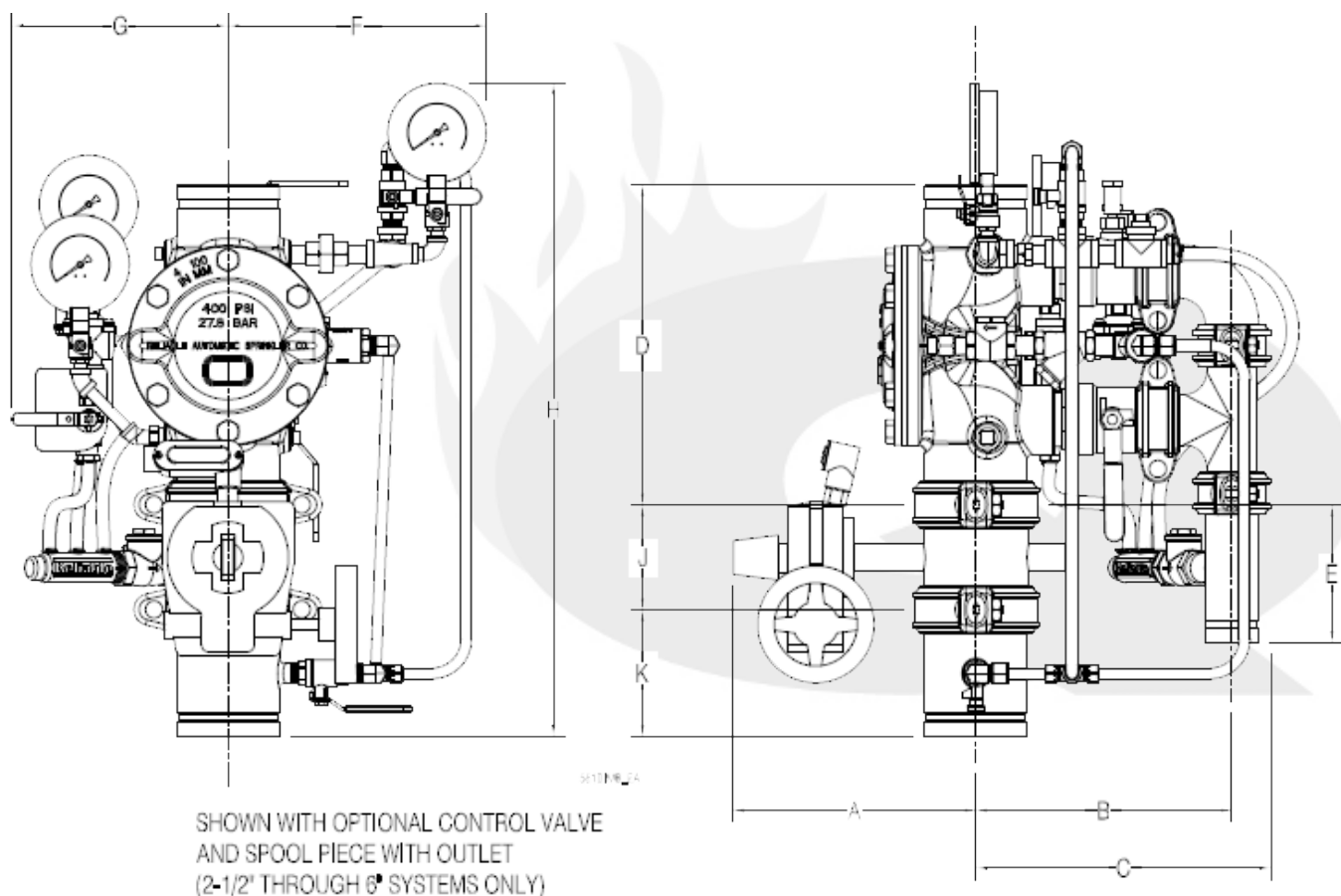

**Note:** 2" grooved drain shown for 4", 6" and 165mm valves. Drain on 2-1/2", 3", and 76mm valves is 1-1/4" threaded with 1-1/4" tee provided for connection of drain piping. Drain on 1-1/2" and 2" valves is 3/4" threaded with 1" tee provided for connection of drain piping.

**TABLE C: Model DDV Dimensions (mm)**

Valve Size	A	B	C	D	E	F	G	H	J	K
1 1/2" (40mm)	117	235	254	203	76	257	203	413	NA	NA
2" (50mm)	124	235	254	203	76	257	203	413	NA	NA
2 1/2" (65mm) & 76mm	241	298	318	279	83	276	222	470	95	140
3" (80mm)	241	298	318	279	83	276	222	470	95	140
4" (100mm)	270	285	327	356	152	289	241	622	114	140
6" (150mm) & 165mm	321	298	340	457	102	327	292	622	146	140

REF: VDRDDV\_032021\_REV0

**AQL PROTECCION**

Carretera N-340 Km 1245, 3 Nave B-5 Polígono industrial El Pla 08750 Molins de Rei, Barcelona (España)  
Tel. (+34) 936800376 \* WhatsApp pedidos: 660781482 \* [www.aqlproteccion.com](http://www.aqlproteccion.com) \* [aql@aqlproteccion.com](mailto:aql@aqlproteccion.com)

**ANBER**

Avda. de las Flores, 13-15 P.E. El Molino 28970 Humanes de Madrid, Madrid (España)  
Tel. (+34) 916063711 \* WhatsApp pedidos: 649787619 \* [www.anber.es](http://www.anber.es) \* [anber@anber.es](mailto:anber@anber.es)

## OPERACIÓN GENERAL

En condiciones normales, la válvula solenoide y la palanca del desbloqueo manual de emergencia de la válvula de diluvio están cerradas manteniendo la presión hidráulica en la cámara del diafragma.

La presión hidráulica capturada mantiene el diafragma cerrado contra el asiento de la válvula. Cuando la válvula solenoide se abre al recibir señal eléctrica o cuando accionamos la apertura manual, aliviamos la presión de la cámara del diafragma al drenaje permitiendo que se suba el diafragma y que el agua fluya a través de la válvula DDV.

El movimiento de agua a través de la línea de suministro a la cámara del diafragma cierra la válvula de retención modelo A que evita que la cámara del diafragma se vuelva a presurizar y que se cierre la válvula de diluvio modelo DDV.

## PUESTA EN MARCHA

1. Asegúrese de que el sistema se haya drenado correctamente y de que aquellas partes del sistema que puedan haber sido afectadas por un incendio se inspeccionen y, si es necesario, se reemplacen.
2. Asegúrese de que el sistema de detección eléctrica esté operativo.
3. Abra las válvulas de drenaje superior e inferior.
4. Asegúrese de que la válvula de accionamiento manual, la válvula solenoide y la válvula de prueba de alarma estén cerradas.
5. Presione y mantenga presionado el émbolo de la válvula de retención modelo A. (Nota: el émbolo debe permanecer presionado hasta que la cámara del diafragma esté completamente presurizada, paso 7).
6. Abra la válvula de suministro de la cámara de diafragma.
7. Con el manómetro de la cámara de presión, confirme que la presión hidráulica total se ha estabilizado en la cámara de presión.
8. Suelte el émbolo de la válvula de retención modelo A.
9. Abra lentamente la válvula principal de suministro de agua hasta que el agua pueda ser vista u oída fluyendo por el desagüe.
10. Cierre lentamente la válvula de drenaje inferior.
11. Con el manómetro de agua arriba, confirme que la presión se ha acumulado debajo del diafragma.
12. Observe si hay fugas de agua a través de la válvula de drenaje superior. Si no produce ninguna fuga, el diafragma de la válvula de diluvio está sellado. Cierre completamente la válvula de drenaje superior.
13. Abra lentamente la válvula principal de suministro de agua. Verifique que la válvula está completamente abierta y debidamente supervisada.
14. Asegúrese que la palanca de accionamiento manual está en posición cerrada.
15. Notifique al personal correspondiente, a los ocupantes del edificio y los responsables de monitorear el sistema que se ha puesto en servicio el sistema.

REF: VDRDDV\_032021\_REVO

### AQL PROTECCION

Carretera N-340 Km 1245, 3 Nave B-5 Polígono industrial El Pla 08750 Molins de Rei, Barcelona (España)  
Tel. (+34) 936800376 \* WhatsApp pedidos: 660781482 \* [www.aqlproteccion.com](http://www.aqlproteccion.com) \* [aql@aqlproteccion.com](mailto:aql@aqlproteccion.com)

### ANBER

Avda. de las Flores, 13-15 P.E. El Molino 28970 Humanes de Madrid, Madrid (España)  
Tel. (+34) 916063711 \* WhatsApp pedidos: 649787619 \* [www.anber.es](http://www.anber.es) \* [anber@anber.es](mailto:anber@anber.es)

## REARME DEL SISTEMA

1. Cierre la válvula de suministro de agua principal.
2. Cierre la válvula de suministro de la cámara del diafragma.
3. Abra la válvula de accionamiento manual.
4. Abra la válvula de drenaje superior y la válvula de drenaje inferior para drenar el sistema.
5. Presione el émbolo de la válvula de retención modelo A para aliviar cualquier presión restante en la línea de suministro a la cámara del diafragma.
6. Abra todas las válvulas de drenaje auxiliares en todo el sistema de protección contra incendios, cerrándolos cuando estén completamente drenados.
7. Inspeccione y reemplace cualquier sección del sistema de protección contra incendios que puede haber sido dañado debido a un incendio.

**FIGURE 3. Model DDV Deluge Valve with Electric Release Trim Components**

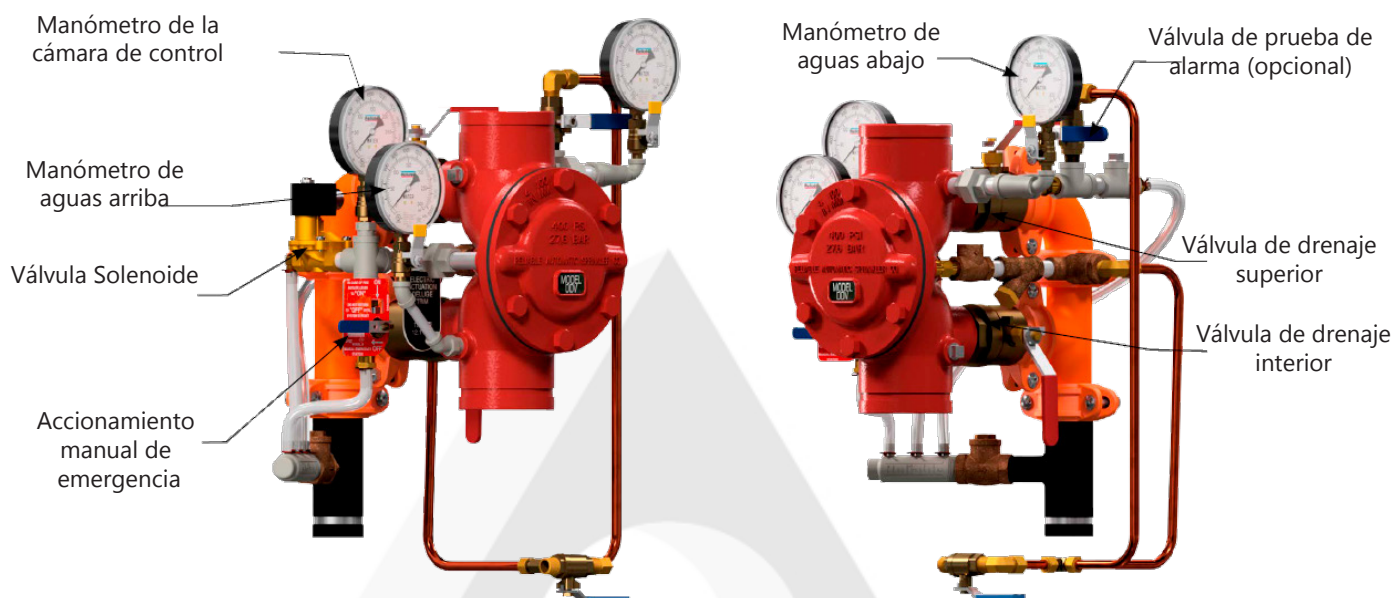

REF: VDRDDV\_032021\_REVO

AQL PROTECCION

Carretera N-340 Km 1245, 3 Nave B-5 Polígono industrial El Pla 08750 Molins de Rei, Barcelona (España)  
Tel. (+34) 936800376 \* WhatsApp pedidos: 660781482 \* [www.aqlproteccion.com](http://www.aqlproteccion.com) \* [aql@aqlproteccion.com](mailto:aql@aqlproteccion.com)

ANBER

Avda. de las Flores, 13-15 P.E. El Molino 28970 Humanes de Madrid, Madrid (España)  
Tel. (+34) 916063711 \* WhatsApp pedidos: 649787619 \* [www.anber.es](http://www.anber.es) \* [anber@anber.es](mailto:anber@anber.es)

## Model DDV Deluge Valve with Wet Pilot Line Trim



### ■ Technical Specifications

Pressure Rating: 27,6 Bar (400 PSI).

### ■ Material Specifications

Body & Cover: Ductile Iron with Red Oxide Epoxy coating and Urethane external coating.

Diaphragm: Fabric reinforced EPDM.

### ■ Actuator

Wet Pilot Detection Line.

### ■ End Connections

See Table A.

### ■ Installation Orientation

Vertical.  
Horizontal.

### ■ Approvals

FM Approved.  
UL Listed.

### ■ Drain Trim Options

See Figure 1.

**FIGURE 4. Model DDV Deluge Valve with Wet Pilot Line Dimensions.**

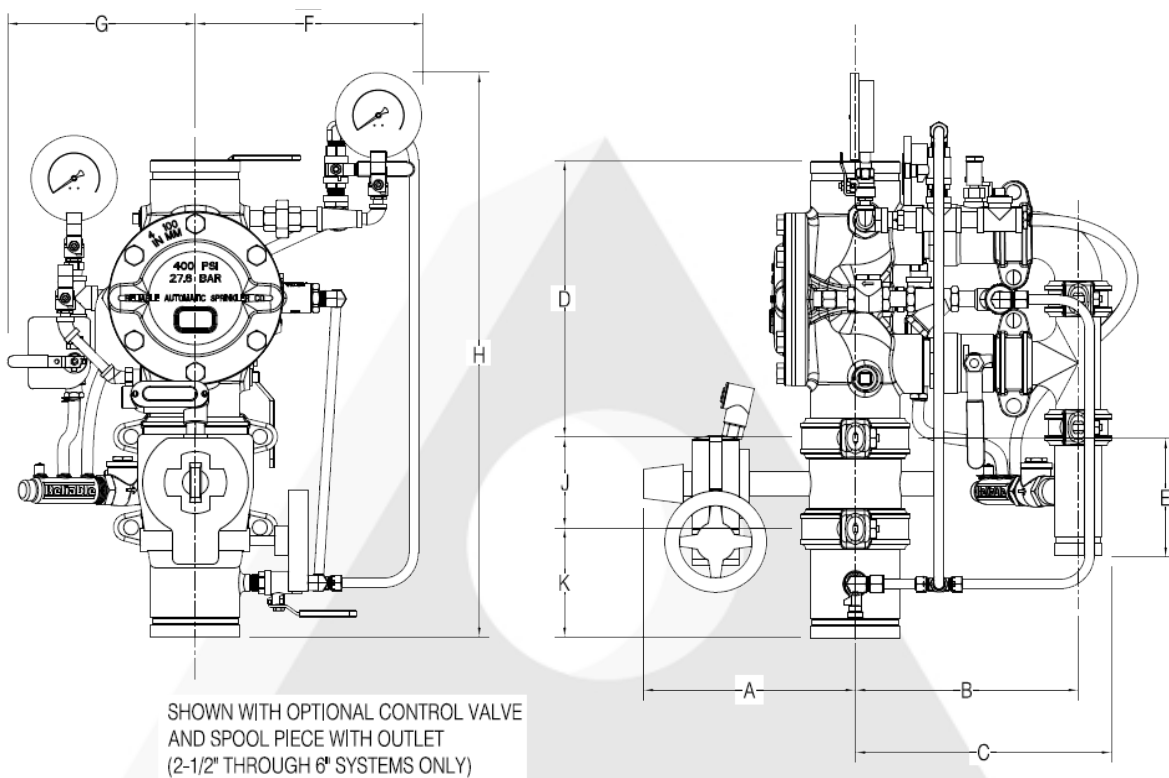

**Note:** 2" grooved drain shown for 4", 6" and 165mm valves. Drain on 2-1/2", 3", and 76mm valves is 1-1/4" threaded with 1-1/4" tee provided for connection of drain piping. Drain on 1-1/2" and 2" valves is 3/4" threaded with 1" tee provided for connection of drain piping.

REF: VDRDDV\_032021\_REV0

AQL PROTECCION

Carretera N-340 Km 1245, 3 Nave B-5 Polígono industrial El Pla 08750 Molins de Rei, Barcelona (España)  
Tel. (+34) 936800376 \* WhatsApp pedidos: 660781482 \* [www.aqlproteccion.com](http://www.aqlproteccion.com) \* [aql@aqlproteccion.com](mailto:aql@aqlproteccion.com)

ANBER

Avda. de las Flores, 13-15 P.E. El Molino 28970 Humanes de Madrid, Madrid (España)  
Tel. (+34) 916063711 \* WhatsApp pedidos: 649787619 \* [www.anber.es](http://www.anber.es) \* [anber@anber.es](mailto:anber@anber.es)

**TABLE D: Model DDV Dimensions (mm)**

Valve Size	A	B	C	D	E	F	G	H	J	K
1 1/2" (40mm)	117	235	254	203	76	257	203	413	NA	NA
2" (50mm)	124	235	254	203	76	257	203	413	NA	NA
2 1/2" (65mm) & 76mm	241	298	318	279	83	276	222	470	95	140
3" (80mm)	241	298	318	279	83	276	222	470	95	140
4" (100mm)	270	285	327	356	152	289	241	622	114	140
6" (150mm) & 165mm	321	298	340	457	102	327	292	622	146	140

## WET PILOT LINE REQUERIMENTS

The wet pilot line is a detection system only and does not contribute to controlling the fire. Piping shall be ½" schedule 40 galvanized pipe and extend from the deluge valve pushrod chamber outlet to the protected area. Maximum wet pilot line height shall be in accordance with the tables below. Wet pilot line shall utilize Reliable Model F-FTR fixed temperature release pilot line detectors spaced and positioned in accordance with the device listing or in accordance with NFPA 72 as fixed temperature heat detectors. Wet pilot lines shall not be installed in an areas subject to freezing, or where temperatures in excess of 150°F (65°C) are anticipated.

**TABLE E: Maximum Wet Pilot Line Height, vertical Valve Orientation**

Water Supply Pressure	1 1/2" , 2"	2 1/2" , 76 mm, 3"	4"	6" , 165 mm
bar (psi)	m	m	m	m
1,4 (20)	7.2	7.7	7.7	6.5
2,6 (40)	17.7	17.3	17.2	15.4
4,1 (60)	26.3	26.8	26.3	25.3
5,5 (80)	36.7	35.0	35.5	34.2
6,9 (100)	45.8	45.2	45.0	43.3
8,3 (120)	55.1	54.3	54.3	51.8
9,7 (140)	64.0	63.9	63.8	58.6
11,0 (160)	73.6	73.4	73.1	66.0
12,4 (180)	82.8	82.4	82.6	75.9
13,4 (200)	92.7	91.9	91.6	88.5
15,2 (220)	100.0	101.2	101.1	97.0
16,6 (240)	110.9	109.7	110.2	105.5
17,9 (260)	119.9	119.6	119.6	114.6
19,3 (280)	129.3	128.9	129.1	122.0
20,7 (300)	134.4	138.7	138.3	135.1
22,1 (320)	147.7	148.0	147.0	142.7
23,4 (340)	156.9	157.4	156.1	151.5
24,8 (360)	167.7	165.6	166.5	161.0
26,2 (380)	176.8	176.0	175.4	141.5
27,6 (400)	186.8	185.4	183.3	176.5

REF: VDRDDV\_032021\_REVO

### AQL PROTECCION

Carretera N-340 Km 1245, 3 Nave B-5 Polígono industrial El Pla 08750 Molins de Rei, Barcelona (España)  
Tel. (+34) 936800376 \* WhatsApp pedidos: 660781482 \* [www.aqlproteccion.com](http://www.aqlproteccion.com) \* [aql@aqlproteccion.com](mailto:aql@aqlproteccion.com)

### ANBER

Avda. de las Flores, 13-15 P.E. El Molino 28970 Humanes de Madrid, Madrid (España)  
Tel. (+34) 916063711 \* WhatsApp pedidos: 649787619 \* [www.anber.es](http://www.anber.es) \* [anber@anber.es](mailto:anber@anber.es)



## GENERAL OPERATION

The wet pilot detection line is a hydraulically pressurized extension of the diaphragm chamber. Under normal conditions the thermal detectors on the wet pilot line and the Manual Release Emergency valve are closed which maintains hydraulic pressure in the diaphragm chamber. The captured hydraulic pressure holds the diaphragm closed against the valve seat. When a thermal detector in the protected area opens, or the Manual Emergency Release valve is opened, hydraulic pressure is relieved from the diaphragm chamber to the drain allowing the diaphragm to relax and water to flow through the Model DDV valve. Water movement through the supply line to the diaphragm chamber closes the Model A Velocity Check Valve which prevents the diaphragm chamber from repressurizing and closing the Model DDV deluge valve. Excessive head pressure on the diaphragm chamber can result in a failure of the valve to operate, therefore, the height of the wet pilot line above the valve is limited to the values shown in Table E in this bulletin. Additional requirements for the wet pilot line are also shown.

## SETUP PROCEDURE

1. Ensure that the system has been properly drained, and all parts of the system that may have been affected by fire are inspected and, if necessary, replaced.
2. Ensure that the wet pilot detection line is in proper working order and that all thermal detection devices are closed.
3. If present, verify that the Alarm Test Valve is closed.
4. Ensure that the Upper and Lower Drain Valves are open.
5. Open the Manual Emergency Release valve.
6. Open the inspectors test valve, or otherwise vent the wet pilot detection line.
7. Depress and hold the plunger on the Model A Velocity Check Valve. (Note: The plunger must remain depressed until the wet pilot detection line is completely filled; step 10).
8. Open the Diaphragm Chamber Supply Valve.
9. Close the Manual Emergency Release valve when a steady stream of water is seen flowing down the drain tube, diverting water pressure to the wet pilot detection line.
10. Close the wet pilot detection line venting device when a steady stream of water is seen exiting the device. Note: Steps 7 and 8 are required to remove trapped air from the wet pilot detection line.
11. Using the Diaphragm Chamber Pressure Gauge, confirm that full hydraulic pressure has stabilized on diaphragm chamber and the wet pilot detection line.
12. Release the plunger on the Model A Velocity Check Valve.
13. Slowly open the main water control valve until water can be seen or heard flowing out the lower drain.
14. Slowly close the Lower Drain Valve.
15. Using the Inlet Pressure Gauge, confirm that full hydraulic pressure has built below the diaphragm.
16. Observe if water leaks through the Upper Drain Valve. If no leak occurs, the deluge valve diaphragm is sealed. Fully close the Upper Drain Valve.
17. Slowly open the main water control valve. Verify that the valve is fully open and properly monitored.
18. If present, verify that the Alarm Test Valve is open.
19. Secure the handle of the Manual Emergency Release valve in the closed position with the provided cable ties.
20. Notify the proper authorities, building occupants, and those responsible for monitoring the system that the system has been placed into service.

REF: VDRDDV\_032021\_REV0

### AQL PROTECCION

Carretera N-340 Km 1245, 3 Nave B-5 Polígono industrial El Pla 08750 Molins de Rei, Barcelona (España)  
Tel. (+34) 936800376 \* WhatsApp pedidos: 660781482 \* [www.aqlproteccion.com](http://www.aqlproteccion.com) \* [aql@aqlproteccion.com](mailto:aql@aqlproteccion.com)

### ANBER

Avda. de las Flores, 13-15 P.E. El Molino 28970 Humanes de Madrid, Madrid (España)  
Tel. (+34) 916063711 \* WhatsApp pedidos: 649787619 \* [www.anber.es](http://www.anber.es) \* [anber@anber.es](mailto:anber@anber.es)

## SHUTDOWN PROCEDURE

1. Close the main water supply control valve.
2. Close the Diaphragm Chamber Supply Valve.
3. Open the Manual Emergency Release Valve.
4. Open the Upper Drain Valve and Lower Drain Valve to drain the system.
5. Depress the plunger on the Model A Velocity Check Valve to relieve any remaining pressure on the supply line to the diaphragm chamber.
6. Open all auxiliary drain valves throughout the fire protection system, closing them when fully drained.
7. Inspect and replace any sections of the fire protection system and wet pilot detection line that may have been damaged due to fire.

**FIGURE 5. Model DDV Deluge Valve with Wet Pilot Line Trim Components**

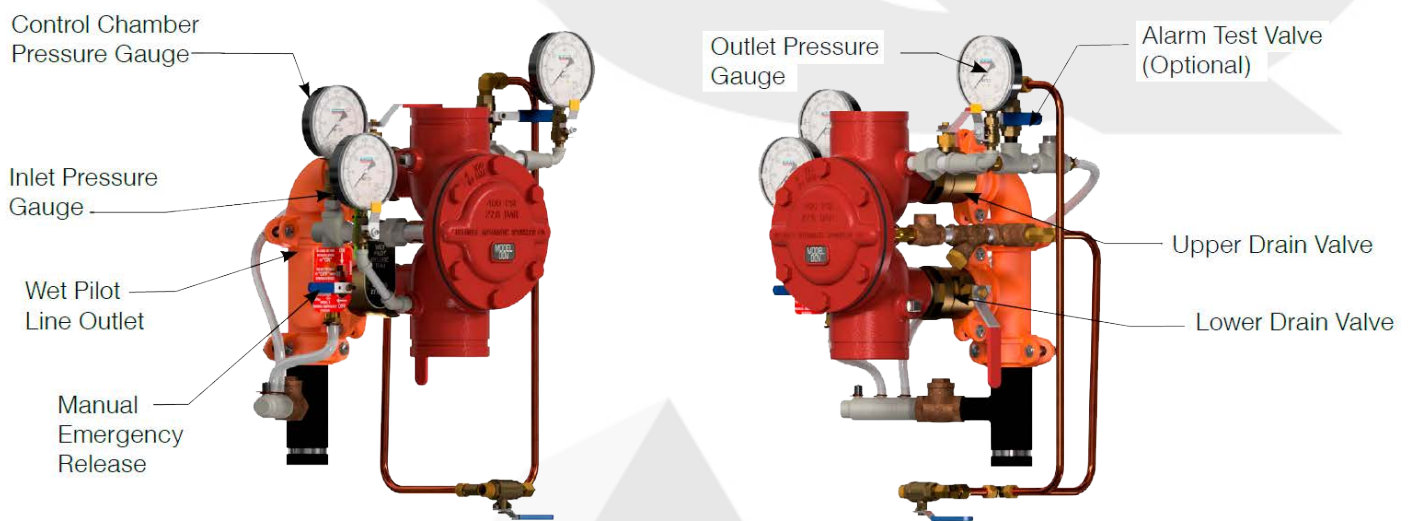

REF: VDRDDV\_032021\_REVO

AQL PROTECCION

Carretera N-340 Km 1245, 3 Nave B-5 Polígono industrial El Pla 08750 Molins de Rei, Barcelona (España)  
Tel. (+34) 936800376 \* WhatsApp pedidos: 660781482 \* [www.aqlproteccion.com](http://www.aqlproteccion.com) \* [aql@aqlproteccion.com](mailto:aql@aqlproteccion.com)

ANBER

Avda. de las Flores, 13-15 P.E. El Molino 28970 Humanes de Madrid, Madrid (España)  
Tel. (+34) 916063711 \* WhatsApp pedidos: 649787619 \* [www.anber.es](http://www.anber.es) \* [anber@anber.es](mailto:anber@anber.es)

## Model DDV Deluge Valve with Dry Pilot Line Trim



### ■ Technical Specifications

Pressure Rating: 27,6 Bar (400 PSI).

### ■ Material Specifications

Body & Cover: Ductile Iron with Red Oxide Epoxy coating and Urethane external coating.

Diaphragm: Fabric reinforced EPDM.

### ■ Actuator

Dry Pilot Detection Line.

### ■ End Connections

See Table A.

### ■ Installation Orientation

Vertical.  
Horizontal.

### ■ Approvals

FM Approved.  
UL Listed.

### ■ Drain Trim Options

See Figure 1.

**FIGURE 6. Model DDV Deluge Valve with Dry Pilot Line Dimensions.**

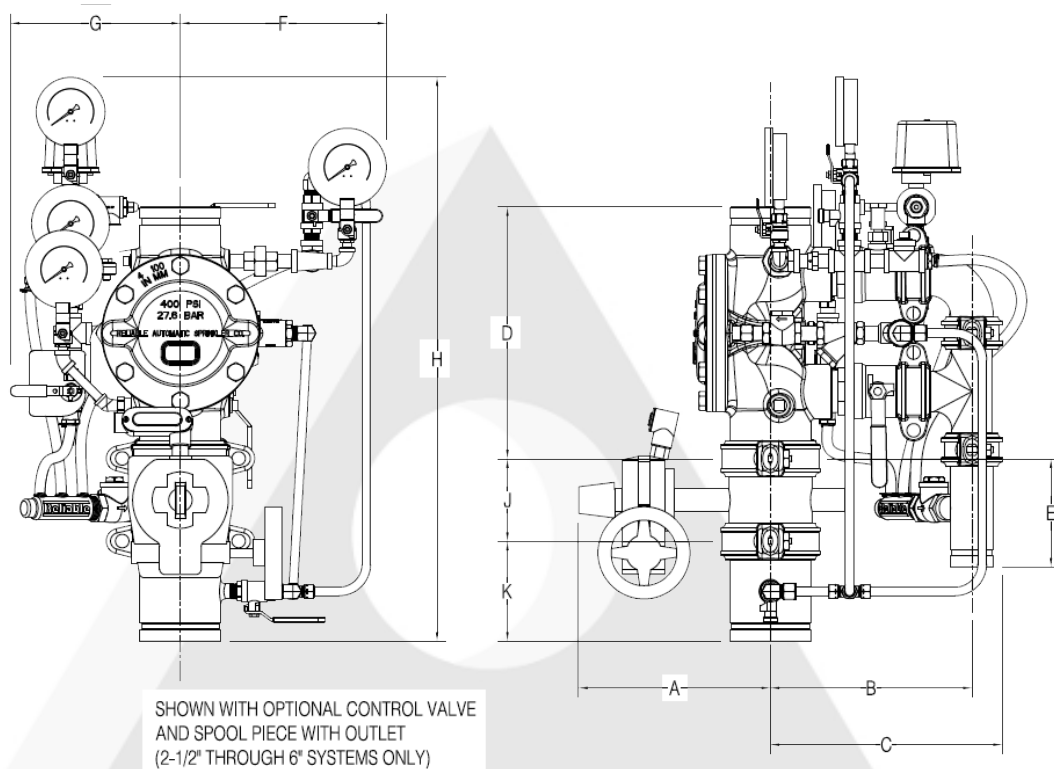

**Note:** 2" grooved drain shown for 4", 6" and 165mm valves. Drain on 2-1/2", 3", and 76mm valves is 1-1/4" threaded with 1-1/4" tee provided for connection of drain piping. Drain on 1-1/2" and 2" valves is 3/4" threaded with 1" tee provided for connection of drain piping.

REF: VDRDDV\_032021\_REV0

AQL PROTECCION

Carretera N-340 Km 1245, 3 Nave B-5 Polígono industrial El Pla 08750 Molins de Rei, Barcelona (España)  
Tel. (+34) 936800376 \* WhatsApp pedidos: 660781482 \* [www.aqlproteccion.com](http://www.aqlproteccion.com) \* [aql@aqlproteccion.com](mailto:aql@aqlproteccion.com)

ANBER

Avda. de las Flores, 13-15 P.E. El Molino 28970 Humanes de Madrid, Madrid (España)  
Tel. (+34) 916063711 \* WhatsApp pedidos: 649787619 \* [www.anber.es](http://www.anber.es) \* [anber@anber.es](mailto:anber@anber.es)

**TABLE F: Model DDV Dimensions (mm)**

Valve Size	A	B	C	D	E	F	G	H	J	K
1 1/2" (40mm)	117	235	254	203	76	257	203	476	NA	NA
2" (50mm)	124	235	254	203	76	257	203	476	NA	NA
2 1/2" (65mm) & 76mm	241	298	318	279	83	276	222	533	95	140
3" (80mm)	241	298	318	279	83	276	222	533	95	140
4" (100mm)	270	285	327	356	152	289	241	686	114	140
6" (150mm) & 165mm	321	298	340	457	102	327	292	686	146	140

## GENERAL OPERATION

The dry pilot detection line is a pneumatically pressurized extension of the diaphragm chamber. Unlike a wet pilot line, dry pilot lines are not limited in height. The Reliable Model LP Dry Pilot Actuator serves to separate the hydraulic pressure in the diaphragm chamber from the pneumatic pressure in the dry pilot line. Under normal conditions the thermal detectors on the dry pilot line are closed which maintains air or nitrogen pressure on the top side of the Model LP Actuator diaphragm.

When properly seated, the Model LP Actuator diaphragm closes the waterway between the Model DDV diaphragm chamber and the drain. The Manual Emergency Release valve, connected directly to the release trim of the diaphragm chamber, is also closed. The captured hydraulic pressure holds the diaphragm closed against the valve seat. When a thermal detector in the protected area opens, pneumatic pressure is released from the dry pilot detection line and the Model LP actuator causing the actuator to open. Hydraulic pressure in the diaphragm chamber is relieved through the Model LP Actuator allowing the diaphragm to relax and water to flow through the Model DDV valve. Alternately, when the Manual Emergency Release valve is opened, hydraulic pressure is directly relieved to the drain, allowing the diaphragm to relax and water to flow through the Model DDV valve. In either case, water movement through the supply line to the diaphragm chamber closes the Model A Velocity Check Valve which prevents the diaphragm chamber from repressurizing and closing the Model DDV deluge valve.

## SHUTDOWN PROCEDURE

1. Close the main water supply control valve.
2. Close the Diaphragm Chamber Supply Valve.
3. Close the valve(s) controlling air or nitrogen supply to the dry pilot detection line.
4. Open the Upper Drain Valve and Lower Drain Valve to drain the system.
5. Depress the plunger on the Model A Velocity Check Valve to relieve any remaining pressure on the supply line to the diaphragm chamber.
6. Open all auxiliary drain valves throughout the fire protection system, closing them when fully drained.
7. Inspect and replace any sections of the fire protection system and dry pilot detection line that may have been damaged due to fire.

REF: VDRDDV\_032021\_REVO

### AQL PROTECCION

Carretera N-340 Km 1245, 3 Nave B-5 Polígono industrial El Pla 08750 Molins de Rei, Barcelona (España)  
Tel. (+34) 936800376 \* WhatsApp pedidos: 660781482 \* [www.aqlproteccion.com](http://www.aqlproteccion.com) \* [aql@aqlproteccion.com](mailto:aql@aqlproteccion.com)

### ANBER

Avda. de las Flores, 13-15 P.E. El Molino 28970 Humanes de Madrid, Madrid (España)  
Tel. (+34) 916063711 \* WhatsApp pedidos: 649787619 \* [www.anber.es](http://www.anber.es) \* [anber@anber.es](mailto:anber@anber.es)

## SETUP PROCEDURE

1. Ensure that the system has been properly drained, and all parts of the system that may have been affected by fire are inspected and, if necessary, replaced.
2. Ensure that the dry pilot detection line is in proper working order and that all thermal detection devices are closed.
3. If present, verify that the Alarm Test Valve is closed.
4. Ensure that the Upper and Lower Drain Valves are open.
5. Open the Manual Emergency Release valve.
6. Depress and hold the plunger on the Model A Velocity Check Valve. (Note: The plunger must remain depressed until the Diaphragm Chamber is fully pressurized; step 12.)
7. Open the Diaphragm Chamber Supply Valve.
8. Close the Manual Emergency Release valve when a steady stream of water is seen flowing down the drain tube, diverting water to the Model LP Actuator.
9. When a steady stream of water is seen flowing from the drain tube of the Model LP Actuator, close the actuator by rapidly pressurizing the dry pilot detection line with air or nitrogen.
10. Place the air or nitrogen supply system into automatic operation. The appropriate air/nitrogen pressure, based upon water pressure, is indicated in Table G.
11. Verify that water flow through the Model LP actuator has stopped, and that proper air or nitrogen pressure is being maintained on the dry pilot detection line.
12. Using the Diaphragm Chamber Pressure Gauge, confirm that full hydraulic pressure has stabilized on diaphragm chamber.
13. Release the plunger on the Model A Velocity Check Valve.
14. Slowly open the main water control valve until water can be seen or heard flowing out the lower drain.
15. Slowly close the Lower Drain Valve.
16. Using the Inlet Pressure Gauge, confirm that full hydraulic pressure has stabilized below the diaphragm.
17. Observe if water leaks through the Upper Drain Valve. If no leak occurs, the deluge valve diaphragm is sealed. Fully close the Upper Drain Valve.
18. Slowly open the main water control valve. Verify that the valve is fully open and properly monitored.
19. If present, verify that the Alarm Test Valve is closed.
20. Secure the handle of the Manual Emergency Release Valve in the closed position with the provided cable ties.
21. Notify the proper authorities, building occupants, and those responsible for monitoring the system that the system has been placed into service.

REF: VDRDDV\_032021\_REVO

### AQL PROTECCION

Carretera N-340 Km 1245, 3 Nave B-5 Polígono industrial El Pla 08750 Molins de Rei, Barcelona (España)  
Tel. (+34) 936800376 \* WhatsApp pedidos: 660781482 \* [www.aqlproteccion.com](http://www.aqlproteccion.com) \* [aql@aqlproteccion.com](mailto:aql@aqlproteccion.com)

### ANBER

Avda. de las Flores, 13-15 P.E. El Molino 28970 Humanes de Madrid, Madrid (España)  
Tel. (+34) 916063711 \* WhatsApp pedidos: 649787619 \* [www.anber.es](http://www.anber.es) \* [anber@anber.es](mailto:anber@anber.es)

**FIGURE 7. Model DDV Deluge Valve with Dry Pilot Line Trim Components**

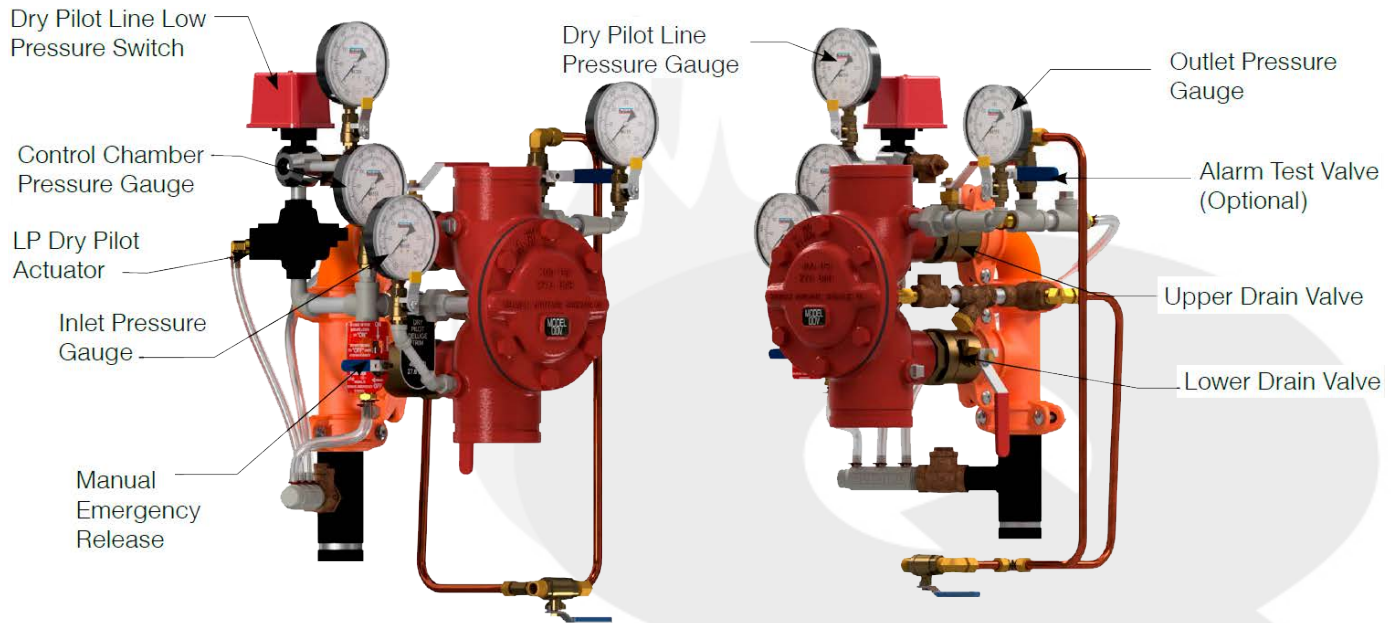

**TABLE G: Dry Pilot Line Pressure**

Water Pressure bar (psi)	Required Dry Pilot Line Pneumatic Pressure bar (psi)
Maximum	Not less Than
1,4 (20)	0,6 (8)
2,1 (30)	0,7 (10)
3,4 (50)	0,8 (12)
5,2 (75)	0,9 (13)
6,9 (100)	1,0 (15)
8,6 (125)	1,1 (16)
10,3 (150)	1,2 (17)
12,1 (175)	1,2 (18)
13,8 (200)	1,3 (19)
15,5 (225)	1,4 (21)
17,2 (250)	1,5 (22)
19,0 (275)	1,6 (23)
20,7 (300)	1,7 (24)
22,4 (325)	1,7 (25)
24,1 (350)	1,8 (26)
25,9 (375)	1,9 (27)
27,6 (400)	1,9 (28)

**Notes:**

- Supervisory air or nitrogen pressure should not exceed 2,1 bar (30 psi). Excess pressure may result in damage to the actuator.
- Fastest valve operation is achieved with supervisory air or nitrogen pressure indicated; however, pressure must never be less than the minimum specified in the table above.
- Air maintenance devices that maintain a constant pressure are recommended; however, if a tank-less compressor is used, the "compressor on" setting of the pressure switch must never be lower than the minimum pressure in the table above.

REF: VDRDDV\_032021\_REVO

**AQL PROTECCION**

Carretera N-340 Km 1245, 3 Nave B-5 Polígono industrial El Pla 08750 Molins de Rei, Barcelona (España)  
 Tel. (+34) 936800376 \* WhatsApp pedidos: 660781482 \* [www.aqlproteccion.com](http://www.aqlproteccion.com) \* [aql@aqlproteccion.com](mailto:aql@aqlproteccion.com)

**ANBER**

Avda. de las Flores, 13-15 P.E. El Molino 28970 Humanes de Madrid, Madrid (España)  
 Tel. (+34) 916063711 \* WhatsApp pedidos: 649787619 \* [www.anber.es](http://www.anber.es) \* [anber@anber.es](mailto:anber@anber.es)

## Model DDV Deluge Valve with Dry Pilot Line Pressure Regulating Trim



- Technical Specifications**  
Pressure Rating: 27,6 Bar (400 PSI).
- Material Specifications**  
Body & Cover: Ductile Iron with Red Oxide Epoxy coating and Urethane external coating.  
Diaphragm: Fabric reinforced EPDM.
- Actuator**  
 Dry Pilot Detection Line.
- End Connections**  
 See Table A.
- Installation Orientation**  
 Vertical.  
 Horizontal.
- Approvals**  
 FM Approved.  
 UL Listed.
- Flow & Pressure Output Range**  
 Reference Table B.
- Drain Trim Options**  
 See Figure 1.

**FIGURE 8. Model DDV Deluge Valve with Dry Pilot Line Pressure Regulating Dimensions.**

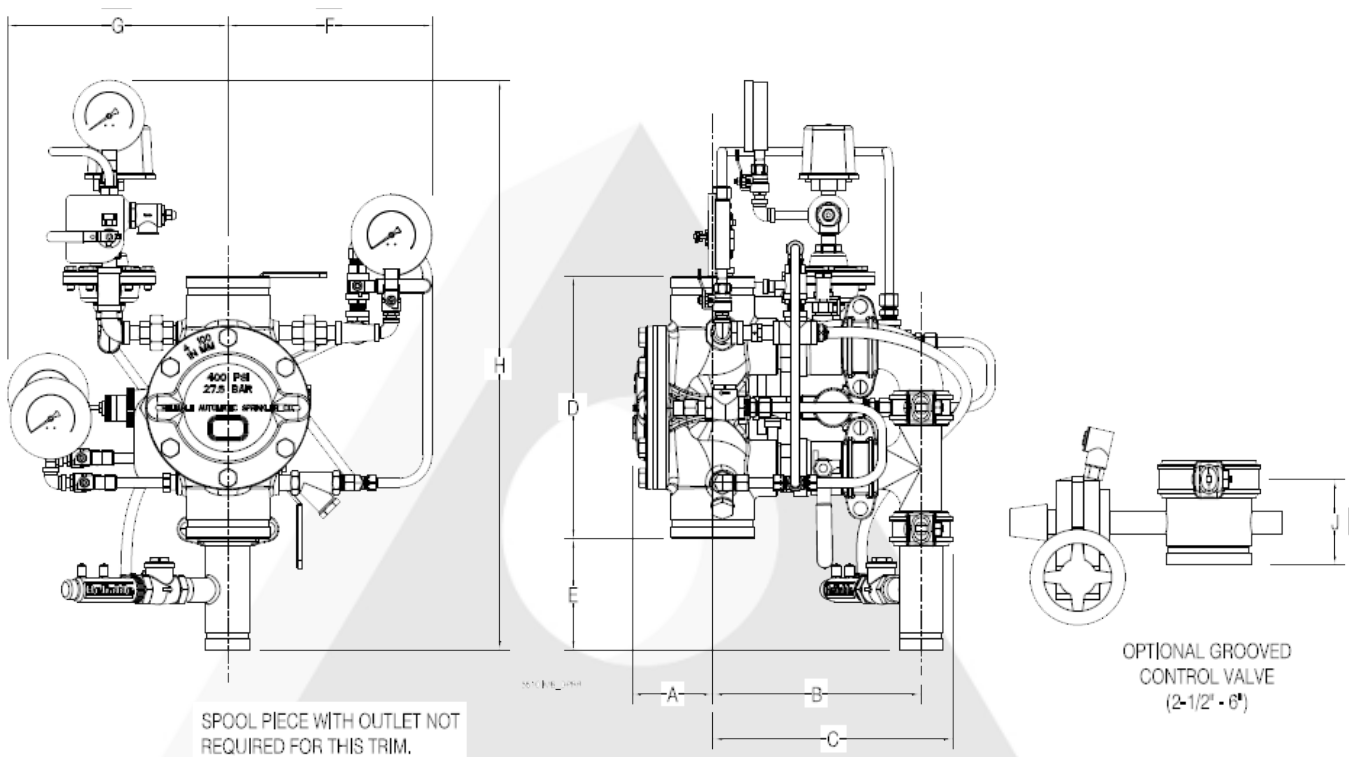

**Note:** 2" grooved drain shown for 4", 6", and 165mm valves. Drain on 1.5" and 2" valves is 3/4" threaded; drain on 2.5", 3", and 76mm valves is 1-1/4" threaded. Threaded tee provided for connection of drain piping.

REF: VDRDDV\_032021\_REV0

AQL PROTECCION  
 Carretera N-340 Km 1245, 3 Nave B-5 Polígono industrial El Pla 08750 Molins de Rei, Barcelona (España)  
 Tel. (+34) 936800376 \* WhatsApp pedidos: 660781482 \* [www.aqlproteccion.com](http://www.aqlproteccion.com) \* [aql@aqlproteccion.com](mailto:aql@aqlproteccion.com)

ANBER  
 Avda. de las Flores, 13-15 P.E. El Molino 28970 Humanes de Madrid, Madrid (España)  
 Tel. (+34) 916063711 \* WhatsApp pedidos: 649787619 \* [www.anber.es](http://www.anber.es) \* [anber@anber.es](mailto:anber@anber.es)

**TABLE H: Model DDV Dimensions (mm)**

Valve Size	A	B	C	D	E	F	G	H	J
1 1/2" (40mm)	72	235	254	203	76	257	267	565	NA
2" (50mm)	72	235	254	203	76	257	267	565	NA
2 1/2" (65mm) & 76mm	90	298	318	279	83	276	286	622	95
3" (80mm)	90	298	318	279	83	276	286	622	95
4" (100mm)	110	285	327	356	152	289	305	775	114
6" (150mm) & 165mm	165	298	340	457	102	327	353	775	146

## GENERAL OPERATION

The dry pilot detection line is a pneumatically pressurized extension of the diaphragm chamber. The Reliable Model LP Dry Pilot Actuator serves to separate the hydraulic pressure in the diaphragm chamber from the pneumatic pressure in the dry pilot line. Under normal conditions the thermal detectors on the dry pilot line are closed which maintains air or nitrogen pressure on the top side of the Model LP Actuator diaphragm.

When properly seated, the Model LP Actuator diaphragm closes the waterway between the Model DDV diaphragm chamber and the drain. The Manual Emergency Release valve, connected directly to the release trim of the diaphragm chamber, is also closed. The captured hydraulic pressure holds the diaphragm closed against the valve seat. When a thermal detector in the protected area opens, pneumatic pressure is released from the dry pilot detection line and the Model LP actuator causing the actuator to open. Hydraulic pressure in the diaphragm chamber is relieved through the Model LP Actuator allowing the diaphragm to relax and water to flow through the Model DDV valve. Alternately, when the Manual Emergency Release valve is opened, hydraulic pressure is directly relieved to the discharge side of the deluge valve, allowing the diaphragm to relax and water to flow through the Model DDV valve. The adjustable pilot valve on the release trim decreases or increases pressure in the diaphragm chamber, thereby regulating the outlet (downstream) flowing pressure.

## SHUTDOWN PROCEDURE

1. Close the main water supply control valve.
2. Close the Diaphragm Chamber Supply Valve.
3. Close the valve(s) controlling air or nitrogen supply to the dry pilot detection line.
4. Open the Upper Drain Valve and Lower Drain Valve to drain the system.
5. Depress the plunger on the Model A Velocity Check Valve to relieve any remaining pressure on the supply line to the diaphragm chamber.
6. Open all auxiliary drain valves throughout the fire protection system, closing them when fully drained.
7. Inspect and replace any sections of the fire protection system and dry pilot detection line that may have been damaged due to fire.

REF: VDRDDV\_032021\_REVO

### AQL PROTECCION

Carretera N-340 Km 1245, 3 Nave B-5 Polígono industrial El Pla 08750 Molins de Rei, Barcelona (España)  
Tel. (+34) 936800376 \* WhatsApp pedidos: 660781482 \* [www.aqlproteccion.com](http://www.aqlproteccion.com) \* [aql@aqlproteccion.com](mailto:aql@aqlproteccion.com)

### ANBER

Avda. de las Flores, 13-15 P.E. El Molino 28970 Humanes de Madrid, Madrid (España)  
Tel. (+34) 916063711 \* WhatsApp pedidos: 649787619 \* [www.anber.es](http://www.anber.es) \* [anber@anber.es](mailto:anber@anber.es)



## SETUP PROCEDURE

1. Ensure that the system has been properly drained, and all parts of the system that may have been affected by fire are inspected and, if necessary, replaced.
2. Ensure that the dry pilot detection line is in proper working order and that all thermal detection devices are closed.
3. If present, verify that the Alarm Test Valve is closed.
4. Ensure that the Upper and Lower Drain Valves are open.
5. Open the Manual Emergency Release valve.
6. Depress and hold the plunger on the Model A Velocity Check Valve. (Note: The plunger must remain depressed until the Diaphragm Chamber is fully pressurized; step 12.)
7. Open the Diaphragm Chamber Supply Valve.
8. Close the Manual Emergency Release valve when a steady stream of water is seen flowing down the drain tube, diverting water to the Model LP Actuator.
9. When a steady stream of water is seen flowing from the drain tube of the Model LP Actuator, close the actuator by rapidly pressurizing the dry pilot detection line with air or nitrogen.
10. Place the air or nitrogen supply system into automatic operation. The appropriate air/nitrogen pressure, based upon water pressure, is indicated in Table G.
11. Verify that water flow through the Model LP actuator has stopped, and that proper air or nitrogen pressure is being maintained on the dry pilot detection line.
12. Using the Diaphragm Chamber Pressure Gauge, confirm that full hydraulic pressure has stabilized on diaphragm chamber.
13. Release the plunger on the Model A Velocity Check Valve.
14. Slowly open the main water control valve until water can be seen or heard flowing out the lower drain.
15. Slowly close the Lower Drain Valve.
16. Using the Inlet Pressure Gauge, confirm that full hydraulic pressure has stabilized below the diaphragm.
17. Observe if water leaks through the Upper Drain Valve. If no leak occurs, the deluge valve diaphragm is sealed. Fully close the Upper Drain Valve.
18. Slowly open the main water control valve. Verify that the valve is fully open and properly monitored.
19. If present, verify that the Alarm Test Valve is closed.
20. Secure the handle of the Manual Emergency Release Valve in the closed position with the provided cable ties.
21. Notify the proper authorities, building occupants, and those responsible for monitoring the system that the system has been placed into service.

REF: VDRDDV\_032021\_REVO

### AQL PROTECCION

Carretera N-340 Km 1245, 3 Nave B-5 Polígono industrial El Pla 08750 Molins de Rei, Barcelona (España)  
Tel. (+34) 936800376 \* WhatsApp pedidos: 660781482 \* [www.aqlproteccion.com](http://www.aqlproteccion.com) \* [aql@aqlproteccion.com](mailto:aql@aqlproteccion.com)

### ANBER

Avda. de las Flores, 13-15 P.E. El Molino 28970 Humanes de Madrid, Madrid (España)  
Tel. (+34) 916063711 \* WhatsApp pedidos: 649787619 \* [www.anber.es](http://www.anber.es) \* [anber@anber.es](mailto:anber@anber.es)

**FIGURE 9. Model DDV Deluge Valve with Dry Pilot Pressure Regulating Trim Components.**

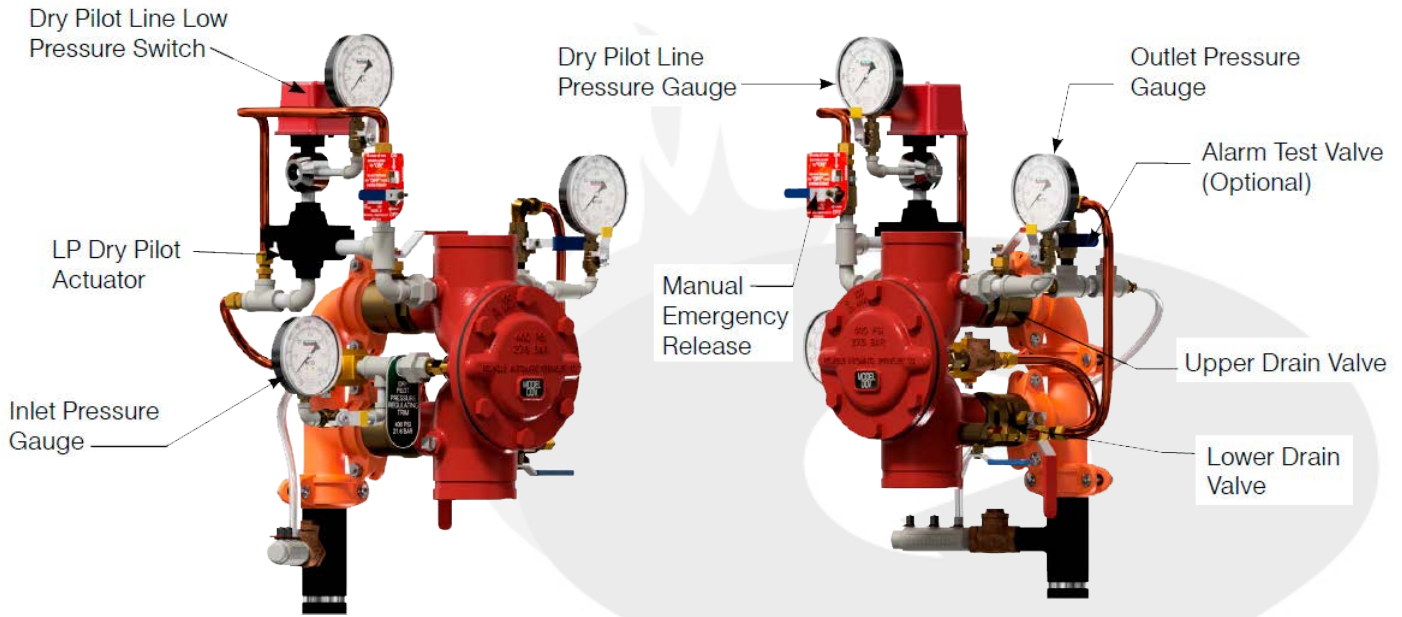

## PRESSURE ADJUSTMENT

1. Loosen the lock nut on the Pilot Regulating Valve adjustment screw..
2. Operate a manual or automatic release to open the Model DDV valve. Note: This will allow water to flow into the fire protection system.
3. Turn the adjustment screw of the pilot regulating device clockwise to increase downstream flowing pressure of the system, or counterclockwise to decrease downstream flowing pressure of the system.
4. Adjust in 1/2 turns and allow time for the valve to stabilize at the new set point.
5. When the desired outlet pressure is reached, securely tighten the locknut.
6. Close the main water control valve and drain the system.
7. Reset the system in accordance with the setup procedure.

**TABLE I: Model DDV Hydraulic Friction Loss Data**

Valve Size	Cv Flow Coefficient gpm/(psi) <sup>1/2</sup>	Kv Flow Coefficient m <sup>3</sup> /h/(bar) <sup>1/2</sup>	Approximate Equivalent Length ft (m) C= 120 Sch 40 Steel Pipe	Approximate Equivalent Length ft (m) C= 100 Sch 40 Steel Pipe
1 1/2" (40mm)	81.6	70	4.6	3.3
2" (50mm)	110.5	95	8.8	6.3
2 1/2" (65mm)	144	124	12.9	9.2
76mm, 3" (80mm)	182	157	24.1	17.2
4" (100mm)	393	339	28.6	20.4
6" (150mm) & 165mm	815	703	52.2	37.2

**Note:** The Cv flow coefficient (amount of flow to generate a 1 psi loss) was used to calculate the approximate equivalent length.

REF: VDRDDV\_032021\_REV0

### AQL PROTECCION

Carretera N-340 Km 1245, 3 Nave B-5 Polígono industrial El Pla 08750 Molins de Rei, Barcelona (España)  
Tel. (+34) 936800376 \* WhatsApp pedidos: 660781482 \* [www.aqlproteccion.com](http://www.aqlproteccion.com) \* [aql@aqlproteccion.com](mailto:aql@aqlproteccion.com)

### ANBER

Avda. de las Flores, 13-15 P.E. El Molino 28970 Humanes de Madrid, Madrid (España)  
Tel. (+34) 916063711 \* WhatsApp pedidos: 649787619 \* [www.anber.es](http://www.anber.es) \* [anber@anber.es](mailto:anber@anber.es)

**FIGURE 10. Optional Alarm Line Test Kit**

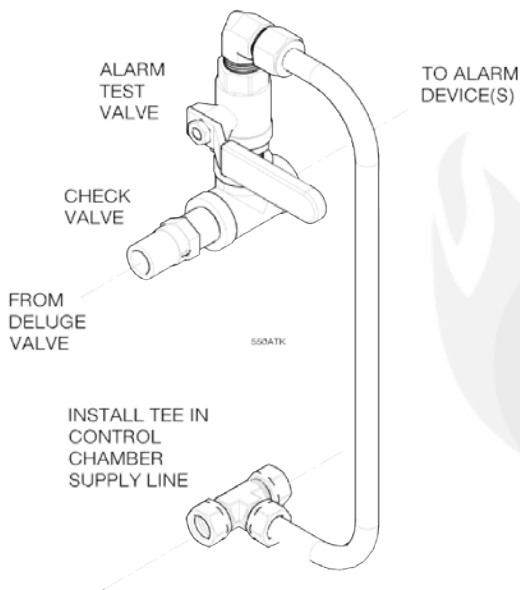

**Note:** When installed in the control chamber supply line, permits testing of alarm devices without the need to operate the Diaphragm Deluge Valve.

The Model DDV valve should be installed in accordance with NFPA 13, "Standard for the Installation of Sprinkler Systems," as well as the requirements of any authorities having jurisdiction. Failure to follow installation instructions and/or revisions to the trim arrangement of the valve may void the warranty and listing of the valve. Verify compatibility of the Model DDV valve's materials with the water supply and the environment where the valve will be installed prior to installation. Do not apply lubricants, sealants, or other chemicals to the diaphragm or seat.

The Model DDV valve must be installed in a location where the temperature is maintained as a minimum of 40°F (4°C). Heat tracing of the valve and trim is not permitted. Design and installation of the detection and release system must be performed in accordance with applicable NFPA standards and the authority having jurisdiction. For Electric Release Valves, at least one electric manual release should be installed near the release control panel to facilitate commissioning and routine testing of the system. Drain should be piped to a location that will avoid damage to property and injury to personnel.

## MAINTENANCE

The owner is responsible for maintaining the fire protection system in proper operating condition. Any system maintenance or testing that involves placing a control valve or detection/control system out of service may eliminate the fire protection that is provided by the fire protection system.

The Reliable Model DDV valve and associated equipment shall periodically be given a thorough inspection and test. NFPA 25, "Inspection, Testing and Maintenance of Water Based Fire Protection Systems," provides minimum maintenance requirements. System components shall be tested, operated, cleaned, and inspected at least annually, and parts replaced as required.

Reliable recommends that the diaphragm be replaced every 10 years or more frequently if inspections identify wear warranting more frequent replacement.

Recommended torque for cover plate bolts is as follows:

- 1-1/2" (40 mm) & 2" (50 mm) = 30 (+/- 5) ft-lb
- 2-1/2" (65 mm), 76 mm, & 3" (80 mm) = 50 (+/- 5) ft-lb
- 4" (100 mm) = 70 (+/- 5) ft-lb
- 6" (150 mm) & 165 mm = 130 (+/- 5) ft-lb

## REPLACEMENT DIAGPHRAGM

- 1-1/2" & 2" - PN 95277620
- 2-1/2", 76mm, & 3" - PN 95277630
- 4" - PN 95277640
- 6" & 165mm - 95277660

## GUARANTEE

For Reliable Automatic Sprinkler Co., Inc. guarantee, terms, and conditions, visit [www.reliablesprinkler.com](http://www.reliablesprinkler.com).

REF: VDRDDV\_032021\_REVO

### AQL PROTECCION

Carretera N-340 Km 1245, 3 Nave B-5 Polígono industrial El Pla 08750 Molins de Rei, Barcelona (España)  
Tel. (+34) 936800376 \* WhatsApp pedidos: 660781482 \* [www.aqlproteccion.com](http://www.aqlproteccion.com) \* [aql@aqlproteccion.com](mailto:aql@aqlproteccion.com)

### ANBER

Avda. de las Flores, 13-15 P.E. El Molino 28970 Humanes de Madrid, Madrid (España)  
Tel. (+34) 916063711 \* WhatsApp pedidos: 649787619 \* [www.anber.es](http://www.anber.es) \* [anber@anber.es](mailto:anber@anber.es)

## ORDERING INFORMATION

Specify the following when ordering:

■ **Valve model:**

DDV

■ **Valve Size:**

1-1/2" (40mm).	3" (80mm).
2" (50mm).	4" (100mm).
2-1/2" (65mm).	6" (150mm).
76mm.	165mm.

■ **End Configuration:**

Grooved, flanged, or threaded (reference Table A)

■ **Operational Trim:**

Electric Actuation 12.7 bar (175 psi).  
 Electric Actuation 20.7 bar (300 psi).  
 Wet Pilot.  
 Dry Pilot.  
 Dry Pilot Pressure Regulating.

■ **Alarm Line Trim:**

No alarm line test (standard)  
 Alarm line test valve (optional)

■ **Drain Trim Options:**

None.  
 Lower Ball Valve.  
 Dual Ball Valves.  
 Full Drain Trim (Note: Full Drain Trim option will arrive disconnected at the couplings/unions).

■ **Grooved Control Valve Option:**

No control valves.  
 Water supply (lower) control valve only.  
 Both water supply (lower) and service (upper) control valves.  
 Note: Control valve option is not available on 1 1/2", 2", 76mm, and 165mm systems.

■ **Pressure Gauge:**

20.7 bar (300 psi) (standard).  
 41.4 bar (600 psi) (optional).

■ **Control Chamber Supply:**

Optional spool piece with 1/2" outlet is available when ordering water supply (lower) control valve.

■ **Alarm Pressure Switch:**

Potter Electric Model PS10-2 (ordered separately)

**FIGURE 11. Model DDV Ordering Information Part Number**

### 6507 U V W X Y Z

Size & End Connections U	Valve Size V	Trims W	Control Valve <sup>(1)</sup> X	Drains Y	Pressure Gauges Z
0 = Red, Groove/Groove	0 = 1 1/2" (40mm) Valve	0 = Wet Pilot	0 = W/O Control Valve	0 = W/ Drain Plugs, W/O Alarm Test	0 = 0-20.7 bar (0-300 psi)
1 = Red, Flange/Flange Class 150	2 = 2" (50mm) Valve	1 = Dry Pilot	1 = W/ Control Valve	1 = W/ 1 Drain Valve, W/O Alarm Test	1 = 0-41.4 bar (0-600 psi)
2 = Red, Flange/Flange Class 300	1 = 2-1/2" (65mm) Valve	2 = Electric	2 = W/ Control Valve & Spool	2 = W/ 2 Drain Valves, W/O Alarm Test	See note <sup>(2)</sup>
3 = Red, Flange/Flange PNIG	7 = 76mm Valve	3 = Dry Pilot Pressure Regulating	3 = W/ 2 Control Valve	3 = W/ Full Drain, W/O Alarm Test	
4 = Red, Flange/Flange BS-E	3 = 3" (80mm) Valve		4 = W/ 2 Control Valves & Spool	4 = W/ Drain Plugs, W/ Alarm Test	Solenoid Valve <sup>(2)</sup> Z
5 = Red, Thread/Thread NPT	4 = 4" (100mm) Valve			5 = 1 Drain Valve, W/ Alarm Test	0 = 12.07 bar (175 psi) Solenoid
6 = Red, Thread/Thread ISO 7/1	6 = 6" (150mm) Valve			6 = W/ 2 Drain Valves, W/ Alarm Test	1 = 20,68 bar (300 psi) Solenoid
	5 = 165mm Valve			7 = W/ Full Drain, W/ Alarm Test	

\*Notes: (1) Control valves and spool piece not available for 1-1/2", 2", 76mm, and 165mm systems.

(2) For electric release deluge systems, Z is used to select pressure rating of solenoid valve. Pressure gauges for electric release will be 300# on inlet and outlet of valve.

REF: VDRDDV\_032021\_REV0

#### AQL PROTECCION

Carretera N-340 Km 1245, 3 Nave B-5 Polígono industrial El Pla 08750 Molins de Rei, Barcelona (España)  
 Tel. (+34) 936800376 \* WhatsApp pedidos: 660781482 \* [www.aqlproteccion.com](http://www.aqlproteccion.com) \* [aql@aqlproteccion.com](mailto:aql@aqlproteccion.com)

#### ANBER

Avda. de las Flores, 13-15 P.E. El Molino 28970 Humanes de Madrid, Madrid (España)  
 Tel. (+34) 916063711 \* WhatsApp pedidos: 649787619 \* [www.anber.es](http://www.anber.es) \* [anber@anber.es](mailto:anber@anber.es)