

MODEL F1S5-FS56 & F1S5-FS42 SPECIAL RESPONSE FLAT SPRAY SPRINKLERS

PRODUCT DESCRIPTION

The F1S5-FS56 and F1S5-FS42 Flat Spray Sprinklers are designed for installation in accordance with CEA 4001 or EN 12845 (Automatic Sprinkler Systems - Design, Installation and Maintenance). The spray pattern created by this sprinkler makes this an excellent choice for applications with lower clearance above the suspended open ceilings and in racks.

The F1S5-FS56 and F1S5-FS42 Flat Spray Sprinkler with shield are used in applications where there are high and lower level sprinklers. The shield is to help prevent the lower level sprinklers from getting wet by the higher level sprinklers.

The F1S5-FS56 and F1S5-FS42 Flat Spray Sprinkler utilize a special response frangible 5.0mm glass bulb. The glass bulb consists of an accurately controlled amount of special fluid hermetically sealed inside of a precisely manufactured glass capsule. This glass bulb is specially constructed to provide fast thermal response.

At normal temperatures, the glass bulb contains the fluid in both the liquid phase and in the vapor phase. The vapor phase can be seen as a small bubble. As heat is applied, the liquid expands forcing the bubble smaller and smaller as the liquid pressure increases. Continued heating forces the liquid to push out against the bulb, causing the glass to shatter, opening the waterway and allowing the deflector to distribute the discharging water.

The F1S5-FS56 and F1S5-FS42 Flat Spray Sprinkler temperature rating are identified by the color of the glass bulb capsule.

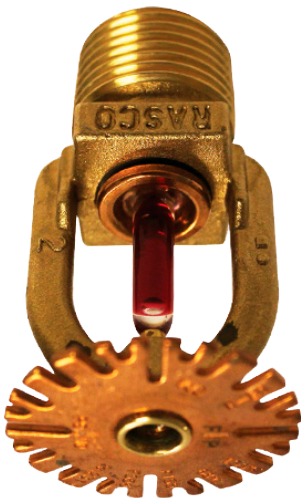

Pendent



Pendent with shield

REF: SRPF1S5_032021_REVO

AQL PROTECCION

Carretera N-340 Km 1245, 3 Nave B-5 Polígono industrial El Pla 08750 Molins de Rei, Barcelona (España)
Tel. (+34) 936800376 * WhatsApp pedidos: 660781482 * www.aqlproteccion.com * aql@aqlproteccion.com

ANBER

Avda. de las Flores, 13-15 P.E. El Molino 28970 Humanes de Madrid, Madrid (España)
Tel. (+34) 916063711 * WhatsApp pedidos: 649787619 * www.anber.es * anber@anber.es

F1S5-FS56

VdS Schadenverhütung GmbH: Certificate G4080046.
CE Certificate: Standard EN 12259-1, EC-Certificate of conformity 0786-CPD-40241.

F1S5-FS42

VdS Schadenverhütung GmbH: Certificate G414024.
CE Certificate: Standard EN 12259-1, Certificate of constancy of performance 0786-CPR-40297.

MODELS F1S5-FS56 AND F1S5-FS42 PENDENT SPRINKLERS

Installation Wrench: Model D Sprinkler Wrench.

Installation Data:

Sprinkler Type Standard-Pendent (SSP) Deflectors Marked to Indicate Position	K-Factor		Sprinkler Height	Approval Organizations	Sprinkler Identification Number (SIN)
	US	Metric			
1/2" (15mm) Standard Orifice with 1/2" NPT Thread	5.6	80	2.25" (57mm)	VdS	RA2314
1/2" (15mm) Standard Orifice with R1/2 Thread	5.6	80	2.25" (57mm)	VdS	RA2314
3/8" (10mm) Standard Orifice with R1/2 Thread	4.2	57	2.25" (57mm)	VdS	RA2315

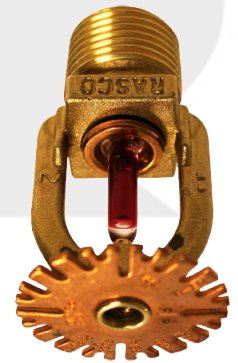

Pendent

MODELS F1S5-FS56 AND F1S5-FS42 PENDENT SPRINKLERS WITH SHIELD

Installation Wrench: Model GFR2 Sprinkler Wrench.

Installation Data:

Nominal Orifice	Thread Size	K-Factor		Sprinkler Height	Approval Organizations	Sprinkler Identification Number (SIN)
		US	Metric			
1/2" (15mm)	1/2" NPT	5.6	80	2.25" (57mm)	VdS	RA2314
1/2" (15mm)	R1/2" BSPT	5.6	80	2.25" (57mm)	VdS	RA2314
3/8" (10mm)	R1/2" BSPT	4.2	57	2.25" (57mm)	VdS	RA2315

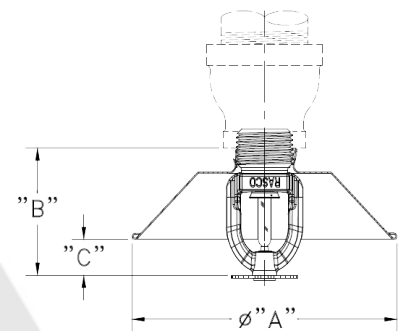

Model F1S5-FS56 with shield

Shield Data:

Part No.	Approvals	"A" Dimension	"B" Dimension	"C" Dimension
6999995574	VdS	4 17/32"(115mm)	1 15/16"(49mm)	9/16"(14mm)

REF: SRPF1S5_032021_REV0

AQL PROTECCION

Carretera N-340 Km 1245, 3 Nave B-5 Polígono industrial El Pla 08750 Molins de Rei, Barcelona (España)
Tel. (+34) 936800376 * WhatsApp pedidos: 660781482 * www.aqlproteccion.com * aql@aqlproteccion.com

ANBER

Avda. de las Flores, 13-15 P.E. El Molino 28970 Humanes de Madrid, Madrid (España)
Tel. (+34) 916063711 * WhatsApp pedidos: 649787619 * www.anber.es * anber@anber.es

APPLICATION

Models F1S5-FS56 and F1S5-FS42 Flat Spray Sprinkler are used in concealed spaces, suspended open ceiling and in racks in accordance with CEA 4001 Sprinkler System Planning) and EN 12845 (Automatic Sprinkler Systems - Design Installation and Maintenance).

INSTALLATION

Models F1S5-FS56 and F1S5-FS42 Flat Spray Sprinklers are special response sprinklers intended for installation as specified in CEA 4001 and EN 12845. They must also be installed with the Model D Sprinkler Wrench specifically designed by Reliable for use with these sprinklers. When installing Models F1S5-FS56 and F1S5-FS42 Pendent with shield use the Model GFR2 Sprinkler Wrench. Any other type of wrench may damage these sprinklers.

Note: A leak tight ½" NPT sprinkler joint can be obtained with a torque of 8-18 ft-lbs (10,8 - 24,4 N-m). Do not tighten sprinklers over maximum recommended torque. It may cause leakage or impairment of the sprinklers.

ORDERING INFORMATION

Specify:

1. Sprinkler Model.
2. Sprinkler Type.
3. Orifice Size.
4. Deflector Type.
5. Temperature Rating.
Specify Bulb Size when ordering.
6. Sprinkler Finish - Bronze only.

Note: When Models F1FR-FS56 and F1FR-FS42 Pendent Sprinklers with shield are ordered, the sprinklers and shields are packaged separately.

REF: SRPF1S5_032021_REVO

AQL PROTECCION

Carretera N-340 Km 1245, 3 Nave B-5 Polígono industrial El Pla 08750 Molins de Rei, Barcelona (España)
Tel. (+34) 936800376 * WhatsApp pedidos: 660781482 * www.aqlproteccion.com * aql@aqlproteccion.com

ANBER

Avda. de las Flores, 13-15 P.E. El Molino 28970 Humanes de Madrid, Madrid (España)
Tel. (+34) 916063711 * WhatsApp pedidos: 649787619 * www.anber.es * anber@anber.es

The Models F1S5-FS56, F1S5-FS42 Pendent, F1S5-FS56 and F1S5-FS42 Pendent Sprinklers with shield should be inspected quarterly. Do not clean sprinklers with soap and water, ammonia or any other cleaning fluid. Remove any sprinkler which has been painted (other than factory applied) or damaged in any way. A stock of spare sprinklers should be maintained to allow quick replacement of damaged or operated sprinklers. Prior to installation, sprinklers should be maintained in the original cartons and packaging until used to minimize the potential for damage to sprinklers that would cause improper operation or nonoperation.

Temperature Ratings:

Classification	Sprinkler Temperature		Max. Ambient Temp.	Bulb Color
	°C	°F		
Ordinary	57	135	100°F (38°C)	Orange
Ordinary	68	155	100°F (38°C)	Red
Intermediate	79	175	150°F (66°C)	Yellow
Intermediate	93	200	150°F (66°C)	Green
High	141	286	225°F (107°C)	Blue

Finish:

Sprinkler	Shield
Bronze	Galvanized

The equipment presented in this bulletin is to be installed in accordance with the latest pertinent Standards of the National Fire Protection Association, Factory Mutual Research Corporation, or other similar organizations and also with the provisions of governmental codes or ordinances whenever applicable. Products manufactured and distributed by Reliable have been protecting life and property for over 80 years, and are installed and serviced by the most highly qualified and reputable sprinkler contractors located throughout the United States, Canada and foreign countries.

REF: SRPF1S5_032021_REVO

AQL PROTECCION

Carretera N-340 Km 1245, 3 Nave B-5 Polígono industrial El Pla 08750 Molins de Rei, Barcelona (España)
Tel. (+34) 936800376 * WhatsApp pedidos: 660781482 * www.aqlproteccion.com * aql@aqlproteccion.com

ANBER

Avda. de las Flores, 13-15 P.E. El Molino 28970 Humanes de Madrid, Madrid (España)
Tel. (+34) 916063711 * WhatsApp pedidos: 649787619 * www.anber.es * anber@anber.es