

MODEL QRM2 AIR COMPRESSORS

Quiet compressors for fire protection systems

Tank-mounted

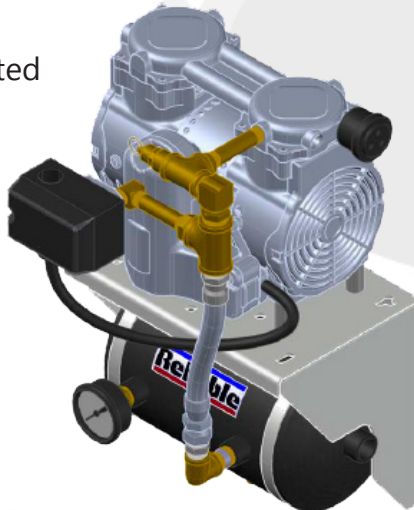

PRODUCT DESCRIPTION

Reliable Model QRM2 Air Compressors provide a compact and quiet compressed air source for dry pipe and preaction fire protection systems. Available in 1/4 HP, 1/2 HP, and 1 HP, the Model QRM2 can be ordered with an integral one-gallon tank. The 1/4 HP and 1/2 HP units produce less than 5.5 CFM (160 L/ min) at 10 psi (0.7 bar) and are therefore also offered without a tank in accordance with NFPA 13 requirements.*

Model QRM2 tankless compressors are available with two factory preset options. For low pressure systems, the compressor is preset to cut-in at 20 psi (1.4 bar) and cut-out at 26 psi (1.8 bar) and is provided with a 76 psi (5.2 bar) safety relief valve. For conventional dry pipe systems, the compressor is preset to cut-in at 40 psi (2.8 bar) and cut-out at 50 psi (3.4 bar) and is provided with a 100 psi (6.9 bar) safety relief valve.

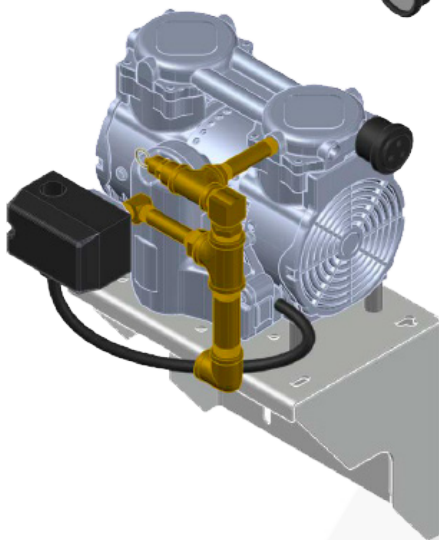

Tank-less

Model QRM2 tank-mounted compressors are factory preset to cut-in at 50 psi (3.5 bar) and cut-out at 70 psi (4.8 bar) and are provided with a 100 psi (6.9 bar) safety relief valve.

All units are mounted to a bracket that can be attached to the riser pipe using the kit provided, or wall mounted using appropriate fasteners provided by the customer. Connection kits for both the tank-mounted and tank-less models are also available and include the required air pressure gauge along with a 1/2" by 30" stainless steel hose. The tank-mounted connection kit also includes a Reliable Model A-2 Pressure Maintenance Device.

REF: VSCRQRM2_092021_REV0

AQL PROTECCION

Carretera N-340 Km 1245, 3 Nave B-5 Polígono industrial El Pla 08750 Molins de Rei, Barcelona (España)
Tel. (+34) 936800376 * WhatsApp pedidos: 660781482 * www.aqlproteccion.com * aql@aqlproteccion.com

ANBER

Avda. de las Flores, 13-15 P.E. El Molino 28970 Humanes de Madrid, Madrid (España)
Tel. (+34) 916063711 * WhatsApp pedidos: 649787619 * www.anber.es * anber@anber.es

Note: NFPA 13 requires a tank-mounted compressor with an approved pressure maintenance device for units that produce more than 5.5 CFM (160 L/min) at 10 psi (0.7 bar). This preferred arrangement is available for all sizes; however, the tank and pressure maintenance device are not mandatory for the 1/4 HP and 1/2 HP models supplying a single system. When supplying more than one system from a single compressor, an approved pressure maintenance device is required for each system; therefore, a tank-mounted compressor must be used.

FEATURES

- Tank-mounted and tank-less options.
- Available in three sizes.
- Convenient riser-mount or wall-mount bracket.
- Quiet, oil-less piston compressor.
- UL listed pressure switch.
- Flexible connection kits.

TABLE A: System Capacity (Based on 30 Minute Fill) and Approximate Sound Level

Motor HP	Hz	System Capacity at 0.7bar (10psi) liters (gallons)	System Capacity at 1.4bar (20psi) liters (gallons)	System Capacity at 2.8bar (40psi) liters (gallons)	Nominal Decibel Rating (dBA)
1/4	60	2309 (610)	1090 (288)	507 (1345)	66
	50	1870 (494)	882 (233)	413 (109)	
1/2	60	4959 (1310)	2218 (586)	984 (260)	68
	50	4016 (1061)	1798 (475)	799 (211)	
1	60	9918 (2620)	4437 (1172)	1968 (520)	70
	50	7874 (2080)	3524 (414)	1567 (414)	

REF: VSCRQRM2_092021_REV0

AQL PROTECCION

Carretera N-340 Km 1245, 3 Nave B-5 Polígono industrial El Pla 08750 Molins de Rei, Barcelona (España)
 Tel. (+34) 936800376 * WhatsApp pedidos: 660781482 * www.aqlproteccion.com * aql@aqlproteccion.com

ANBER

Avda. de las Flores, 13-15 P.E. El Molino 28970 Humanes de Madrid, Madrid (España)
 Tel. (+34) 916063711 * WhatsApp pedidos: 649787619 * www.anber.es * anber@anber.es

FIGURE 1 - 1/4 HP Dimensions.

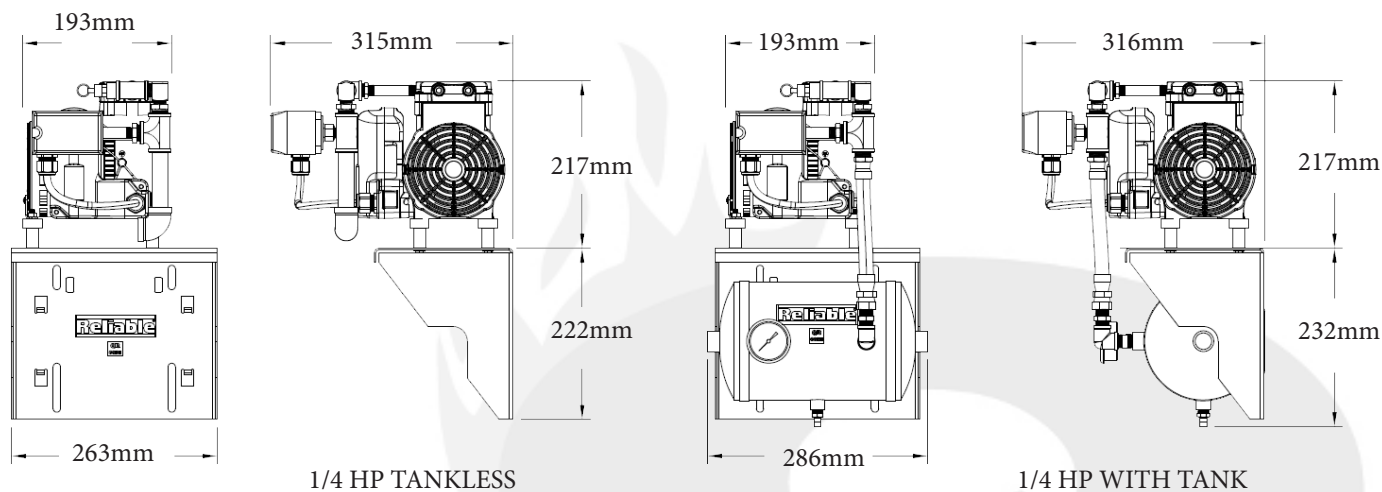
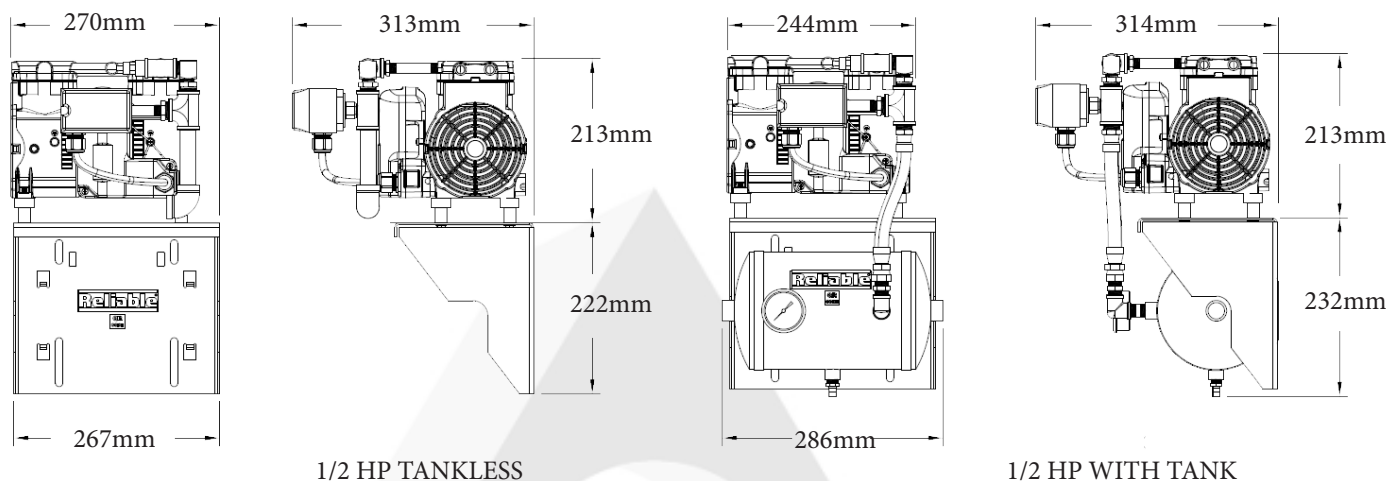

FIGURE 2 - 1/2 HP Dimensions.



REF: VSCRQM2_092021_REV0

AQL PROTECCION

Carretera N-340 Km 1245, 3 Nave B-5 Polígono industrial El Pla 08750 Molins de Rei, Barcelona (España)
Tel. (+34) 936800376 * WhatsApp pedidos: 660781482 * www.aqlproteccion.com * aql@aqlproteccion.com

ANBER

Avda. de las Flores, 13-15 P.E. El Molino 28970 Humanes de Madrid, Madrid (España)
Tel. (+34) 916063711 * WhatsApp pedidos: 649787619 * www.anber.es * anber@anber.es

FIGURE 3 - 1 HP Dimensions.

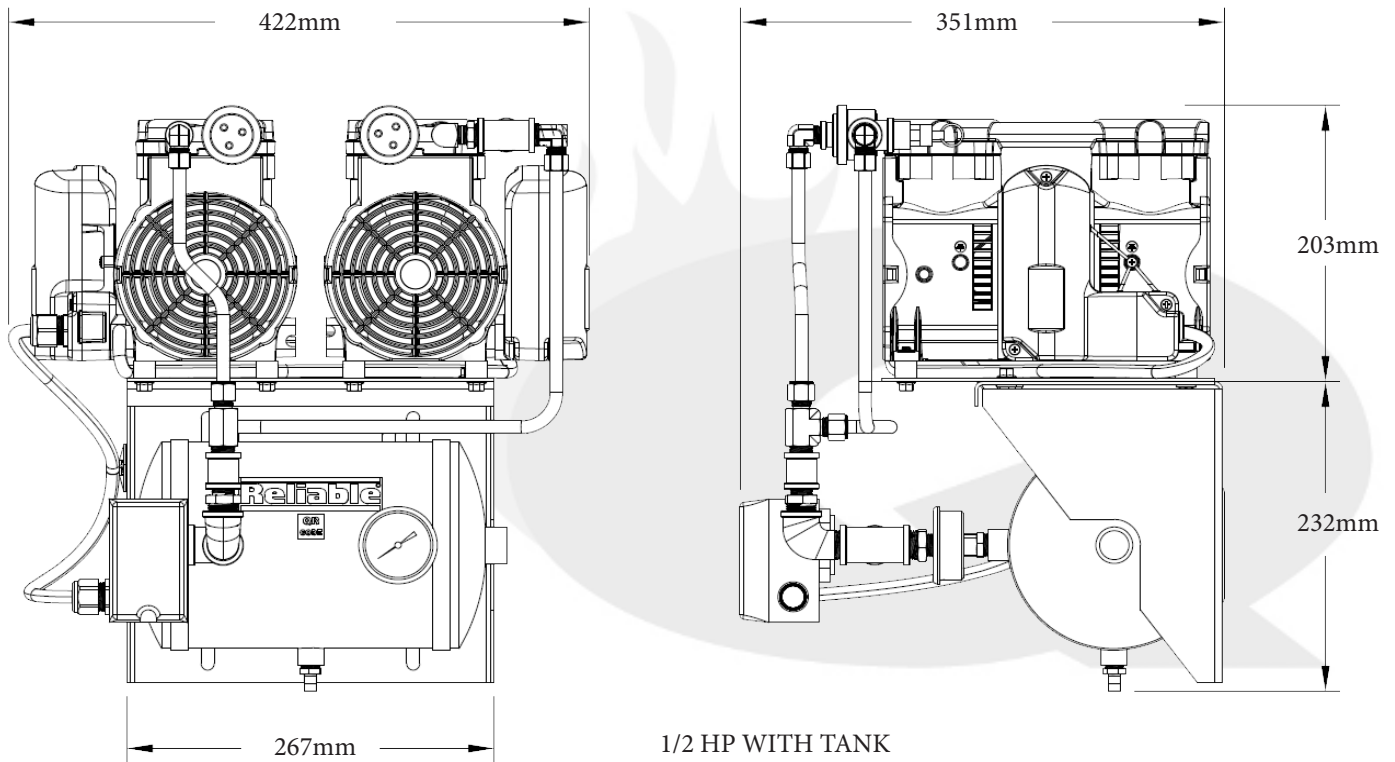
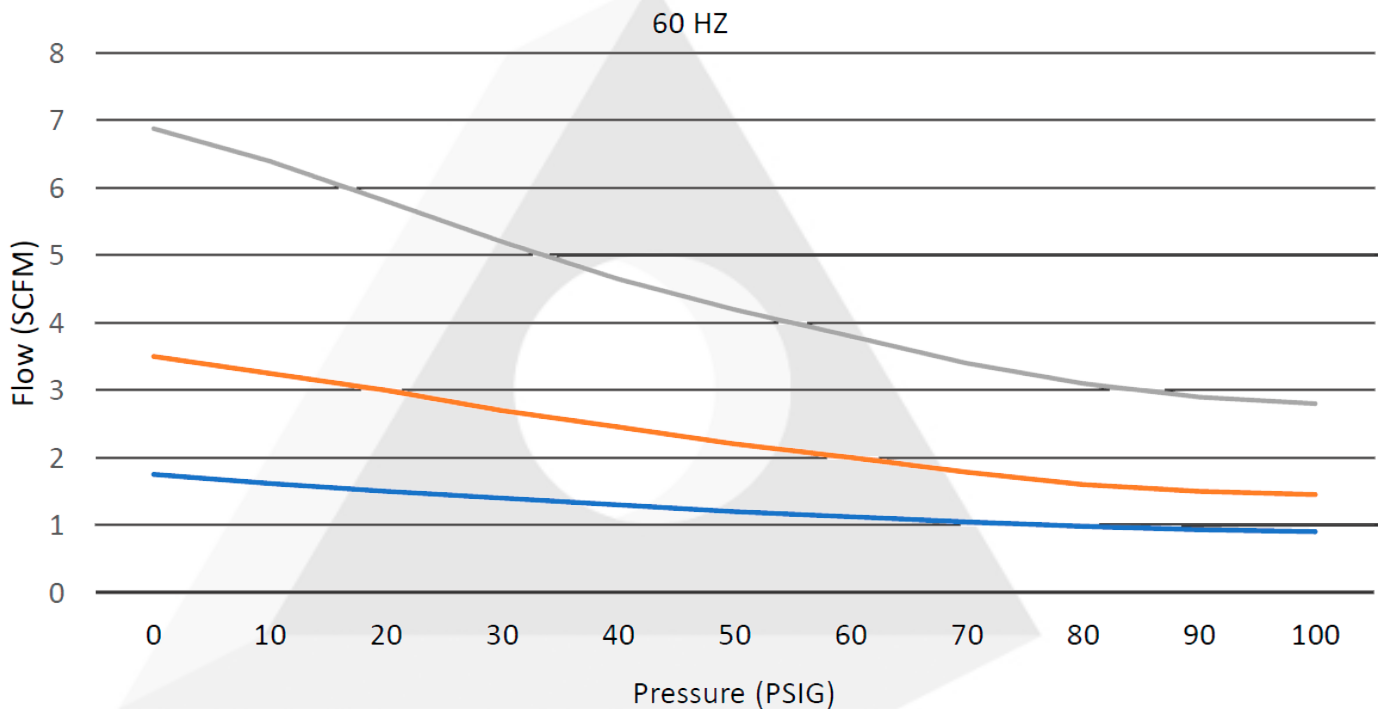

FIGURE 4 - 60 Hz Model Performance



REF: VSCRQRM2_092021_REV0

AQL PROTECCION

Carretera N-340 Km 1245, 3 Nave B-5 Polígono industrial El Pla 08750 Molins de Rei, Barcelona (España)
 Tel. (+34) 936800376 * WhatsApp pedidos: 660781482 * www.aqlproteccion.com * aql@aqlproteccion.com

ANBER

Avda. de las Flores, 13-15 P.E. El Molino 28970 Humanes de Madrid, Madrid (España)
 Tel. (+34) 916063711 * WhatsApp pedidos: 649787619 * www.anber.es * anber@anber.es

FIGURE 5 - 50 Hz Model Performance

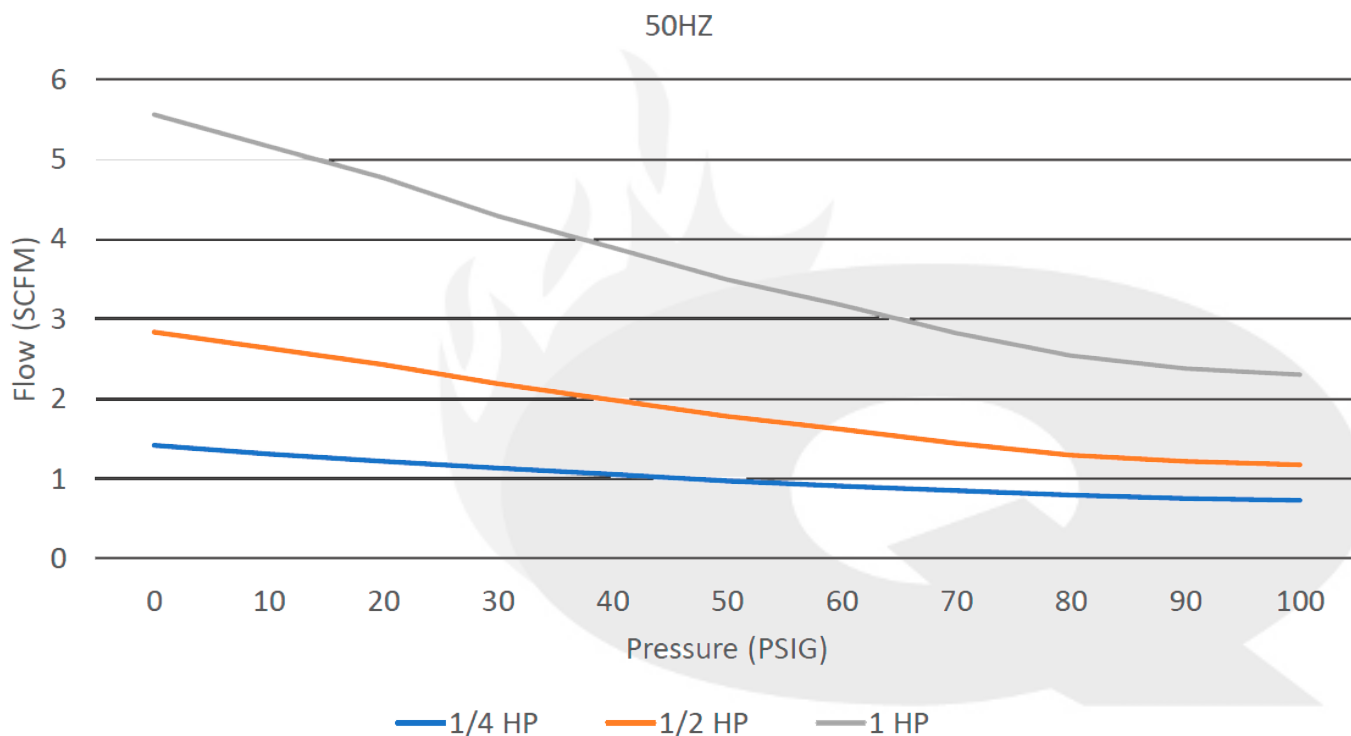

TABLE B: Electrical Characteristics

Motor HP	Voltage / Hz	Full Load Amperage	Start Up Amperage
1/4	115 / 60	4.8	29
	220 / 60	1.8	11
	220 / 50	2.1	12.6
1/2	115 / 60	6.4	38
	220 / 60	3.7	22
	220 / 50	2.3	13.8
1	115 / 60	12.8	77
	220 / 60	7.4	44
	220 / 50	4.5	27

Note: Wire size to be in accordance with National Electrical Code, but in no case less than 12 gauge.

REF: VSCRQRM2_092021_REV0

FIGURE 6 - Connection Kits

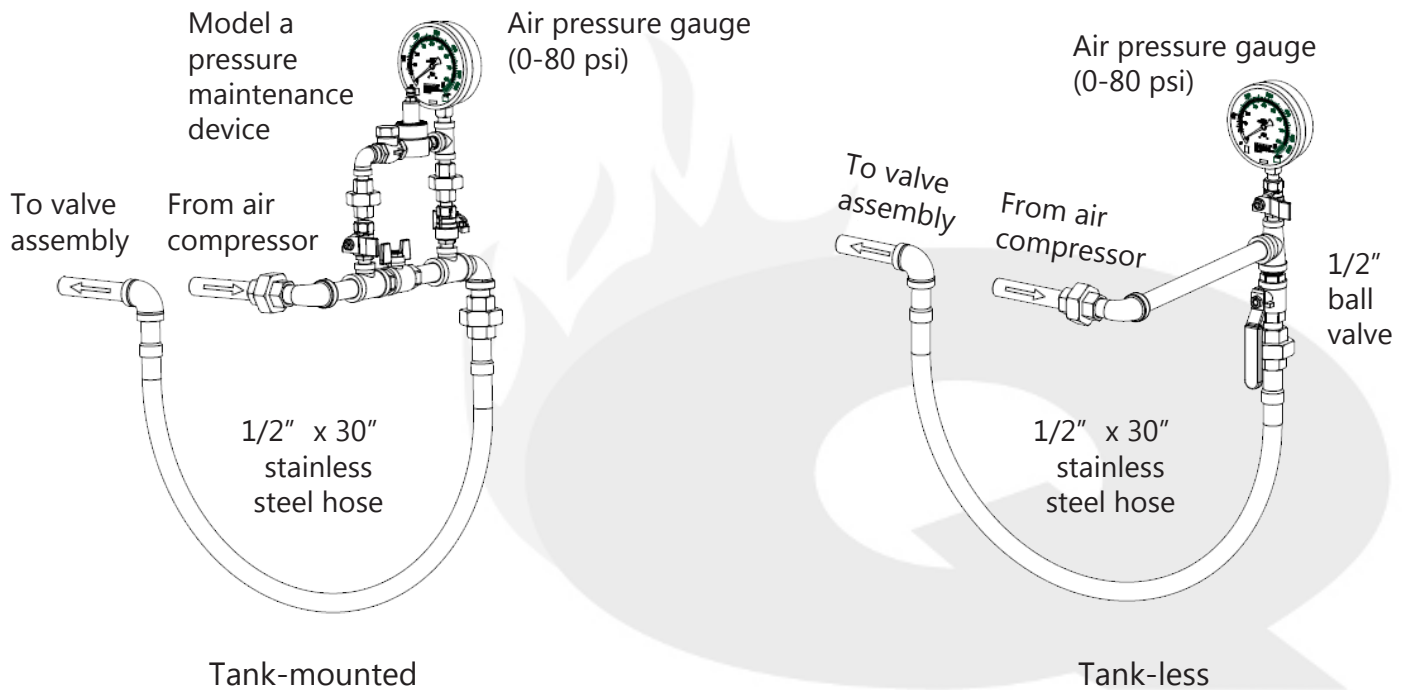

Notes:

1. See *Reliable Bulletin #251* for additional information on Model A Pressure Maintenance Device.
2. 1/2" x 30" stainless steel hose may be purchased separately (P/N 6872000000).

INSTALLATION

The compressor must be mounted in a flat, level, horizontal orientation. Locate the compressor in a clean, well ventilated area where the minimum temperature is maintained between 40° F (4° C) and 104° F (40° C). Provide at least 12" of clearance on all sides from walls or other obstructions that may interfere with airflow over and through the compressor.

The compressor must be wired in accordance with the National Electric Code to a properly grounded circuit using minimum 12-gauge wire. When necessary, pressure adjustment can be made by turning the Main Calibration Screw under the cover of the pressure switch. This will increase both the cut-in and cut-out pressures without affecting the differential. Adjustment of the Differential Pressure Screw is not recommended.

Please refer "QRM2 Series Installation, Operation, and Maintenance Manual", for additional information.

REF: VSCRQRM2_092021_REVO

AQL PROTECCION

Carretera N-340 Km 1245, 3 Nave B-5 Polígono industrial El Pla 08750 Molins de Rei, Barcelona (España)
Tel. (+34) 936800376 * WhatsApp pedidos: 660781482 * www.aqlproteccion.com * aql@aqlproteccion.com

ANBER

Avda. de las Flores, 13-15 P.E. El Molino 28970 Humanes de Madrid, Madrid (España)
Tel. (+34) 916063711 * WhatsApp pedidos: 649787619 * www.anber.es * anber@anber.es

MAINTENANCE

The owner is responsible for maintaining all parts of the fire protection system in proper operating condition. Any system maintenance or testing that involved placing a system component out of service may eliminate the fire protection that is provided by the fire protection system.

The Reliable Model QRM2 Air Compressor shall periodically be given a thorough inspection and test. NFPA 25, "Inspection, Testing, and Maintenance of Water Based Fire Protection Systems," provides minimum maintenance requirements.

System components shall be tested, operated, cleaned, and inspected at least annually and parts replaced as required.

ORDERING INFORMATION

Specify the following when ordering.

- Model:
 - QRM2 1/4 HP Tank-less (Low Pressure, 20 - 26 psi).
 - QRM2 1/4 HP Tank-less (Conventional Pressure, 40 - 50 psi).
 - QRM2 1/2 HP Tank-less (Low Pressure, 20 - 26 psi).
 - QRM2 1/2 HP Tank-less (Conventional Pressure, 40 - 50 psi).
 - QRM2 1/4 HP Tank Mounted.
 - QRM2 1/2 HP Tank Mounted.
 - QRM2 1 HP Tank Mounted.

- Voltage:
 - 115VAC/60 Hz.
 - 220VAC/60 Hz.
 - 220VAC/50 Hz.

- Optional Connection Kit:
 - Tank-less.
 - Tank-mounted.
 - 1/2" x 30" Stainless Steel Hose Only.

Caution: Use of the tank-mounted connection kit with a tankless compressor will result in short cycling of the compressor.

REF: VSCRQRM2_092021_REV0

AQL PROTECCION

Carretera N-340 Km 1245, 3 Nave B-5 Polígono industrial El Pla 08750 Molins de Rei, Barcelona (España)
Tel. (+34) 936800376 * WhatsApp pedidos: 660781482 * www.aqlproteccion.com * aql@aqlproteccion.com

ANBER

Avda. de las Flores, 13-15 P.E. El Molino 28970 Humanes de Madrid, Madrid (España)
Tel. (+34) 916063711 * WhatsApp pedidos: 649787619 * www.anber.es * anber@anber.es