

# MODEL **MBEC-14** EXTENDED COVERAGE HORIZONTAL SIDWALL SPRINKLER **K14 (200METRIC)**

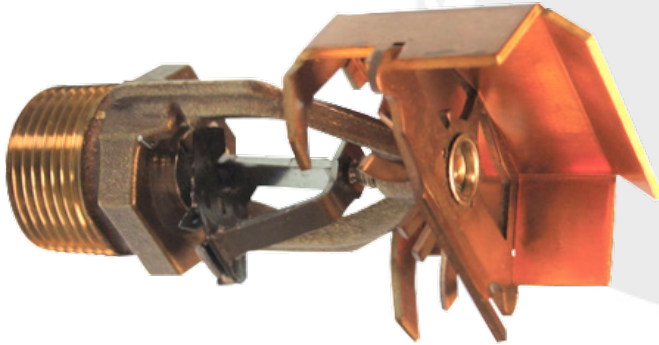

## PRODUCT DESCRIPTION

The Reliable Model MBEC-14 is an extended coverage horizontal sidewall sprinkler utilizing a sensitive solder link thermal element.

The MBEC-14 provides a greater coverage area and lower discharge pressure than smaller orifice standard coverage horizontal sidewall sprinklers.

The Model MBEC-14 is cULus listed as a standard-response sprinkler for storage protection (control mode specific application) in accordance with NFPA13, and is FM Approved as a quickresponse sprinkler for protection of HC-1 and HC-2 non-storage areas in accordance with Property Loss Prevention Data Sheet 3-26.

Hydraulic calculations are based upon the density/area method in accordance with NFPA 13 or FM Global Data Sheets. Please see the Design Criteria section for additional design criteria for the Model MBEC sprinkler.

The Model MBEC-14 is primarily intended for the protection of pre-engineered metal buildings (PEMB) having a roof slope of 2 inches rise over 12 inches run (9.5°) or less with maximum 25 ft (7.6m) wide bays. The unique design of the sprinkler allows the branch lines to be supported on each side of the main steel girders rather than from the lightweight steel purlins and direct spray toward the middle of the bay (see Figures 2 and 3).

Table A provides a summary of the approvals and availability of the Model MBEC-14 sprinkler. Additional technical information is provided on the following pages.

## FEATURES

- Coverage areas up to 175 ft<sup>2</sup> (16.3m<sup>2</sup>).
- K-factor 14.0 (200) permits low discharge pressure.
- Specially suited for installation in pre-engineered metal buildings.
- Permitted for use on wet, dry, and preaction systems.

REF: SRHMBEC14\_052022\_REV0

### AQL PROTECCION

Carretera N-340 Km 1245, 3 Nave B-5 Polígono industrial El Pla 08750 Molins de Rei, Barcelona (España)  
Tel. (+34) 936800376 \* WhatsApp pedidos: 660781482 \* [www.aqlproteccion.com](http://www.aqlproteccion.com) \* [aql@aqlproteccion.com](mailto:aql@aqlproteccion.com)

### ANBER

Avda. de las Flores, 13-15 P.E. El Molino 28970 Humanes de Madrid, Madrid (España)  
Tel. (+34) 916063711 \* WhatsApp pedidos: 649787619 \* [www.anber.es](http://www.anber.es) \* [anber@anber.es](mailto:anber@anber.es)

## DESIGN CRITERIA (GENERAL)

**Design Method:** Density/Area.

**Minimum Operating Pressure:** 7 psi (12 bar).

**Maximum Coverage Area:** 14'-0" x 12'-6" (4.3m x 3.8m).

**Maximum Sprinkler Spacing on Branchline:** 14'-0".

**Minimum Sprinkler Spacing Along Branchline:**

7'-0" (2.1m) for cULus.

8'-0" (2.4m) for FM.

**Maximum Bay Width:** 25'-0" (7.6m).

**Roof Slope:** 2:12 (9.5°) or less.

**Deflector Orientation:** Parallel to Floor.

## SPECIFIC CULUS STORAGE CRITERIA

**Maximum Storage Height:** 12'-0" (3.7m).

**Minimum Clear Height:** 10'-0" (3m) (Top of Storage to Deflector).

**Maximum Building Height:** 32'-0" (9.8m).

**Permitted Storage (as defined by NFPA 13):**

- Miscellaneous Storage of Class I-IV Commodities, Group A Plastics, Rubber Tires, and Roll Paper.
- Idle Pallet Storage.

*Table A. Model MBEC-14 Extended Coverage Horizontal Sidewall Sprinkler Summary.*

Style	Orientation	K-factor gpm/psi <sup>1/2</sup> (lpm/bar <sup>1/2</sup> )	Max. Working pressure psi(bar)	Listings & Approvals	Sprinkler Identification Number (SIN)
<b>MBEC</b>	Horizontal Sidewall	14.0 (200)	175 (12.0) (FM)	cULus, FM	R6932

### *Model H Wrench.*



REF: SRHMBEC14\_052022\_REV0

AQL PROTECCION

Carretera N-340 Km 1245, 3 Nave B-5 Polígono industrial El Pla 08750 Molins de Rei, Barcelona (España)  
Tel. (+34) 936800376 \* WhatsApp pedidos: 660781482 \* [www.aqlproteccion.com](http://www.aqlproteccion.com) \* [aql@aqlproteccion.com](mailto:aql@aqlproteccion.com)

ANBER

Avda. de las Flores, 13-15 P.E. El Molino 28970 Humanes de Madrid, Madrid (España)  
Tel. (+34) 916063711 \* WhatsApp pedidos: 649787619 \* [www.anber.es](http://www.anber.es) \* [anber@anber.es](mailto:anber@anber.es)

**Technical Specifications:**

**Style:** EC Horizontal Sidewall.  
**Threads:** 3/4" NPT or ISO 7-1R3/4.  
**Nominal K-factor:** 14.0 (200 metric).

**Material Specifications:**

**Thermal Sensor:** Nickel Alloy Solder Link.  
**Sprinkler Frame:** Brass Alloy.  
**Button/Cup:** Brass alloy.  
**Sealing Assembly:** Brass with PTFE.  
**Load Screw:** Bronze.  
**Deflector:** Bronze Alloy.  
**Levers:** Bronze alloy.  
**Ejection Spring:** Stainless Steel.

**Sprinklers Finishes:**

**cULus:** Brass, Chrome.  
**FM:** Brass only.

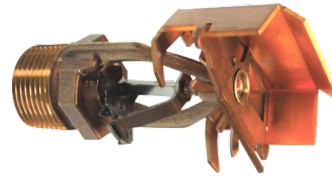

**Sensitivity:**

**cULus:** Standard Response.  
**FM:** Quick Response.

**Temperature Ratings:**

165°F (74°C).  
 212°F (100°C)

**Listings and Approvals:**

**cULus** (Storage)<sup>(1)</sup>.  
**FM Approved** (non-storage).

<sup>(1)</sup> See design criteria on page 1 for specific criteria.

Figure 1. MBEC-14 Components and Dimensions.

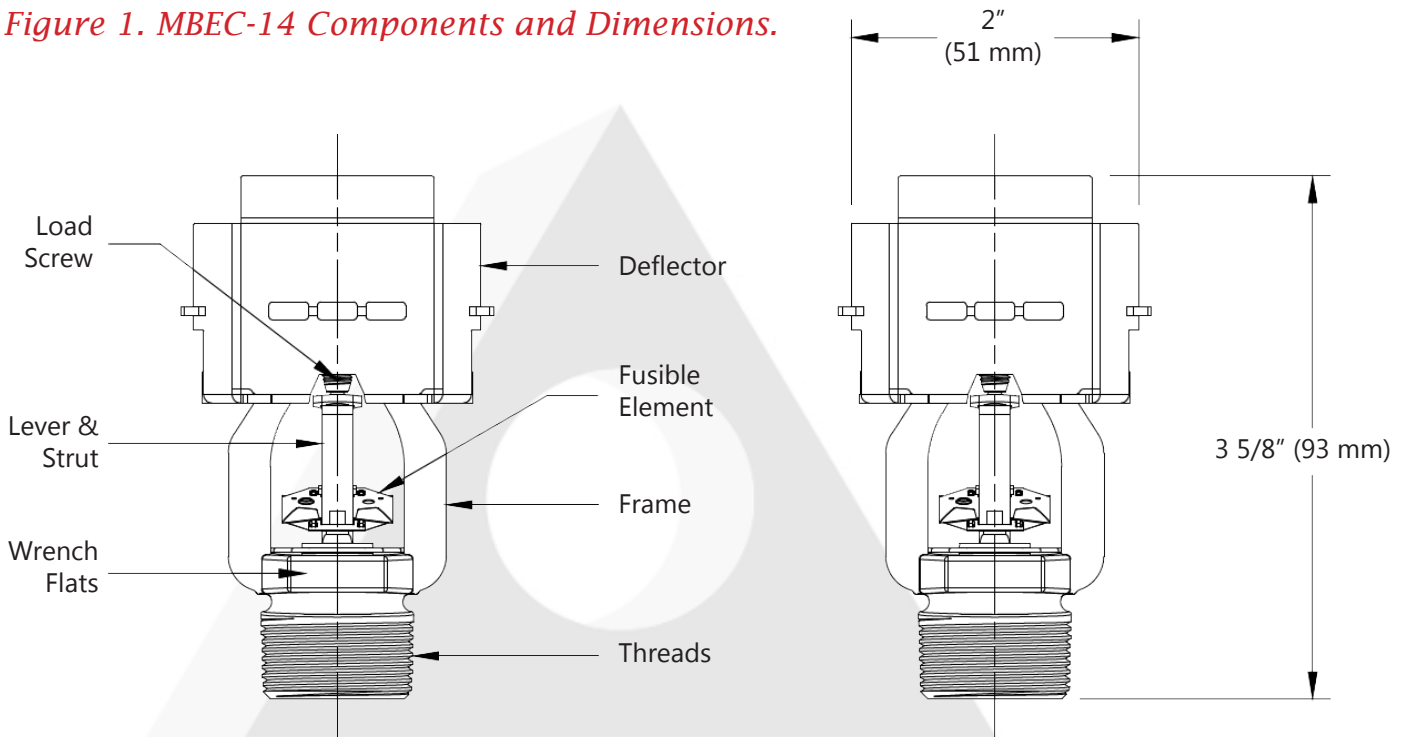

Note: For purposes of setting deflector distance, the top of the deflector is 1/2" (13mm) above the centerline of the sprinkler orifice.

REF: SRHMBEC14\_052022\_REV0

AQL PROTECCION

Carretera N-340 Km 1245, 3 Nave B-5 Polígono industrial El Pla 08750 Molins de Rei, Barcelona (España)  
 Tel. (+34) 936800376 \* WhatsApp pedidos: 660781482 \* [www.aqlproteccion.com](http://www.aqlproteccion.com) \* [aql@aqlproteccion.com](mailto:aql@aqlproteccion.com)

ANBER

Avda. de las Flores, 13-15 P.E. El Molino 28970 Humanes de Madrid, Madrid (España)  
 Tel. (+34) 916063711 \* WhatsApp pedidos: 649787619 \* [www.anber.es](http://www.anber.es) \* [anber@anber.es](mailto:anber@anber.es)

**Figure 2. Installation Detail A.**

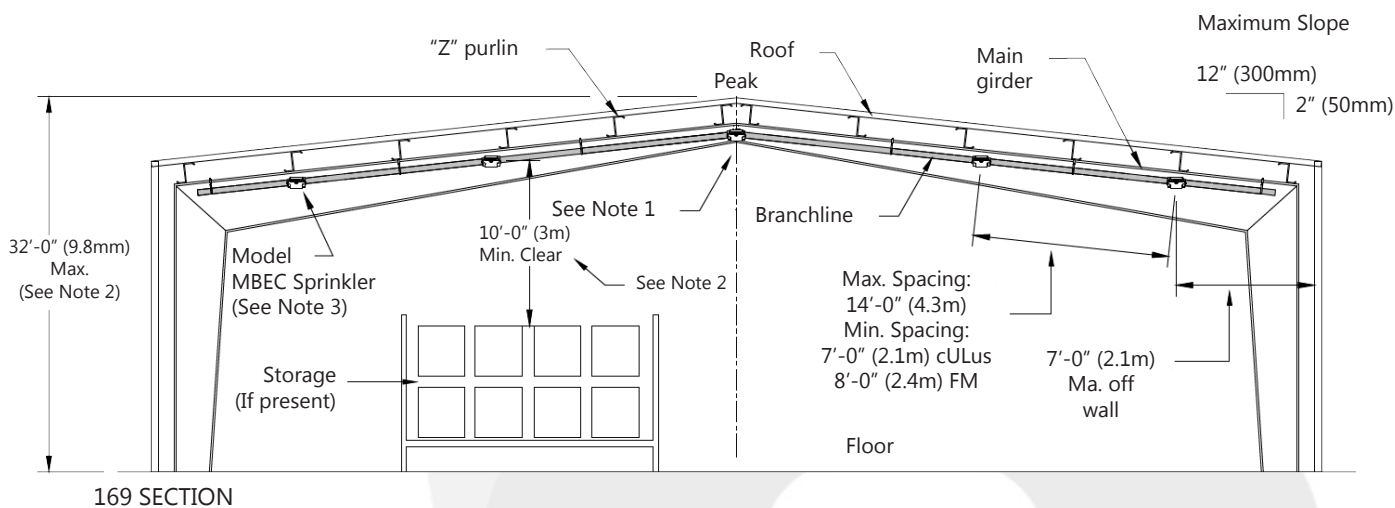

**NOTES:**

1. Where sprinkler is not located at center of building directly under peak, sprinklers must be within 4 ft. (1.2m) of peak on each side.
2. For cULus Listing only when used as a listed storage sprinkler.
3. Align deflector horizontal (parallel to floor).

**Figure 3. Installation Detail B.**

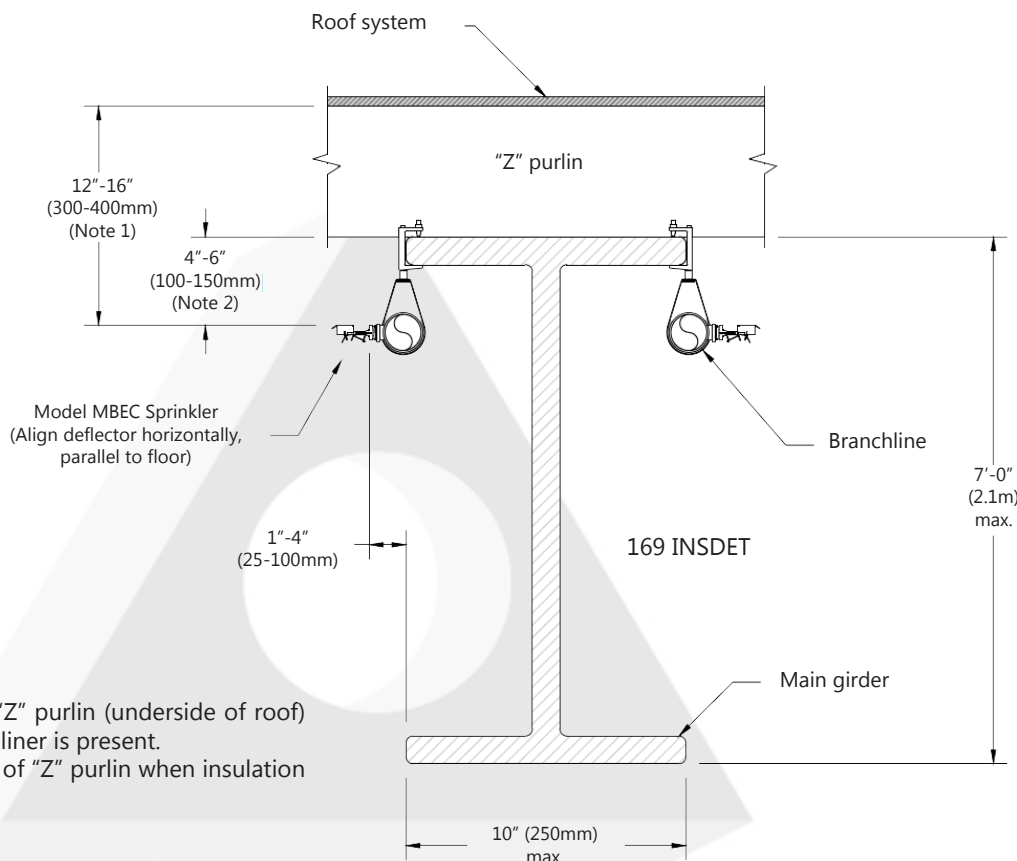

**NOTES:**

1. Measure to top of "Z" purlin (underside of roof) when no insulation or liner is present.
2. Measure to bottom of "Z" purlin when insulation and liner is present.

REF: SRHMBEC14\_052022\_REV0

**AQL PROTECCION**

Carretera N-340 Km 1245, 3 Nave B-5 Polígono industrial El Pla 08750 Molins de Rei, Barcelona (España)  
 Tel. (+34) 936800376 \* WhatsApp pedidos: 660781482 \* [www.aqlproteccion.com](http://www.aqlproteccion.com) \* [aql@aqlproteccion.com](mailto:aql@aqlproteccion.com)

**ANBER**

Avda. de las Flores, 13-15 P.E. El Molino 28970 Humanes de Madrid, Madrid (España)  
 Tel. (+34) 916063711 \* WhatsApp pedidos: 649787619 \* [www.anber.es](http://www.anber.es) \* [anber@anber.es](mailto:anber@anber.es)

## INSTALLATION

Reliable Model MBEC-14 sprinklers are intended for installation in accordance with NFPA 13 and FM Loss Prevention Data Sheets, as well as the requirements of any authorities having jurisdiction using only the Reliable Model H installation wrench. Any other type of wrench may damage the sprinkler. A leak-tight sprinkler joint can be obtained by tightening to between 14-20 lb-ft (19-27 N-m) torque. Exceeding the maximum recommended torque may cause leakage or impairment of the sprinkler. Damaged sprinklers must be replaced immediately.

**Caution:** When handling sprinklers, hold sprinklers only by the frame arms and do not apply any force on the link assembly.

Failure to follow these installation instructions may result in leaks, inadvertent operation, or non-operations of sprinklers.

## MAINTENANCE

Reliable Model MBEC-14 sprinklers should be inspected and the sprinkler system maintained in accordance with NFPA 25, as well as the requirements of any Authorities Having Jurisdiction.

Prior to installation, sprinklers should remain in the original cartons and packaging until used. This will minimize the potential for damage to sprinklers that could cause improper operation or non-operation.

Do not clean sprinklers with soap and water, ammonia liquid or any other cleaning fluids. Remove dust by gentle vacuuming without touching the sprinkler.

Replace any sprinkler which has been painted (other than factory applied).

Once operated, automatic sprinklers cannot be reassembled and/ or reused. A stock of spare sprinklers should be maintained to allow quick replacement of damaged or operated sprinklers.

Failure to properly maintain sprinklers may result in inadvertent operation or non-operation during a fire event.

## ORDERING INFORMATION

### Specify:

**Model Sprinkler:**

- MBEC-14 Sprinkler

**Temperature Rating:**

- 165°F (74°C)
- 212°F (100°C)

**End Connection:**

- 3/4 NPT
- ISO7-1R3/4 (BSPT)

**Finish:**

- Brass (cULus, FM)
- Chrome (cULus only)

## GUARANTEE

For the Reliable Automatic Sprinkler Co., Inc. guarantee, terms, and conditions, visit [www.reliablesprinkler.com](http://www.reliablesprinkler.com).

REF: SRHMBEC14\_052022\_REV0

### AQL PROTECCION

Carretera N-340 Km 1245, 3 Nave B-5 Polígono industrial El Pla 08750 Molins de Rei, Barcelona (España)  
Tel. (+34) 936800376 \* WhatsApp pedidos: 660781482 \* [www.aqlproteccion.com](http://www.aqlproteccion.com) \* [aql@aqlproteccion.com](mailto:aql@aqlproteccion.com)

### ANBER

Avda. de las Flores, 13-15 P.E. El Molino 28970 Humanes de Madrid, Madrid (España)  
Tel. (+34) 916063711 \* WhatsApp pedidos: 649787619 \* [www.anber.es](http://www.anber.es) \* [anber@anber.es](mailto:anber@anber.es)