

SPRINKLER GUARDS, GUARDS WITH SHIELDS, AND WATER SHIELDS



Example: Model C1 Sprinkler Guard

PRODUCT DESCRIPTION

Sprinkler guards and water shields in this bulletin are independent components which are Listed or Approved with specific fire sprinklers. Sprinkler guards are designed to protect the sprinkler from damage due to incidental contact. Water shields are intended for use in racks or under grated walkways and prevent water from above from cooling and thereby delaying activation of the shielded sprinkler.

Refer to the guard selection table in this bulletin and sprinkler technical bulletins for listing and approval information regarding sprinkler and guard combinations.

Note: guards, shields and guard/shield combinations are NOT compatible with recessed sprinkler installations.

Model C Guards and Guard/Shield Assemblies

Model C-1 Guard

This guard is used with pendent, upright, horizontal sidewall, and vertical sidewall sprinklers and does not incorporate a water shield.

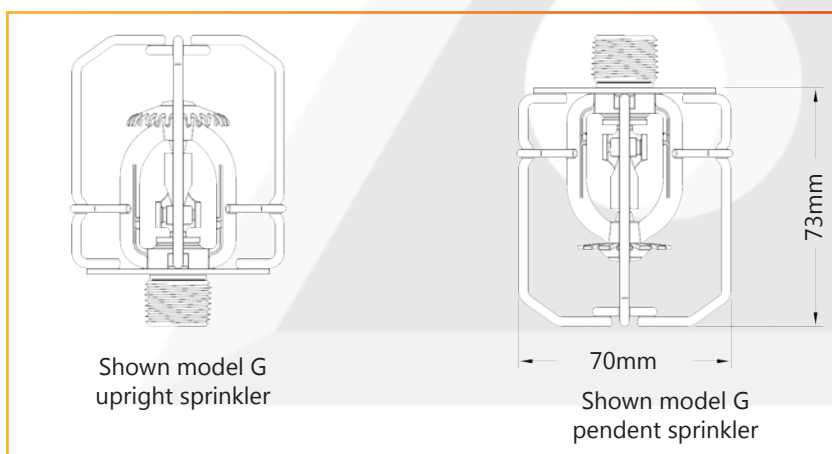

REF: SJR_082022_REV2

AQL PROTECCION

Carretera N-340 Km 1245, 3 Nave B-5 Polígono industrial El Pla 08750 Molins de Rei, Barcelona (España)
Tel. (+34) 936800376 * WhatsApp pedidos: 660781482 * www.aqlproteccion.com * aql@aqlproteccion.com

ANBER

Avda. de las Flores, 13-15 P.E. El Molino 28970 Humanes de Madrid, Madrid (España)
Tel. (+34) 916063711 * WhatsApp pedidos: 649787619 * www.anber.es * anber@anber.es

Model C-2 Guard

This guards is used with non-recessed dry pendent sprinklers.

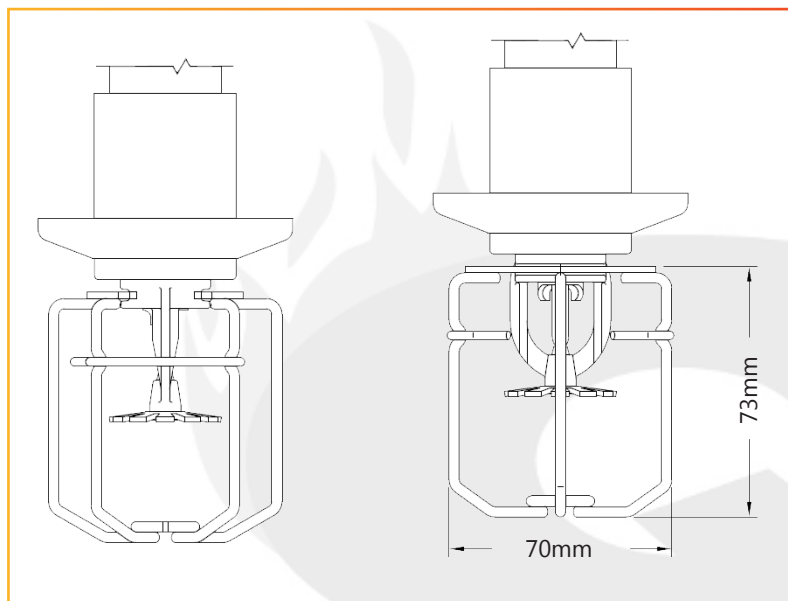

Model C-3 Guards

This guard have a built-in water shield. When assembled to an upright sprinkler, the combination forms an upright intermediate sprinkler with guard.

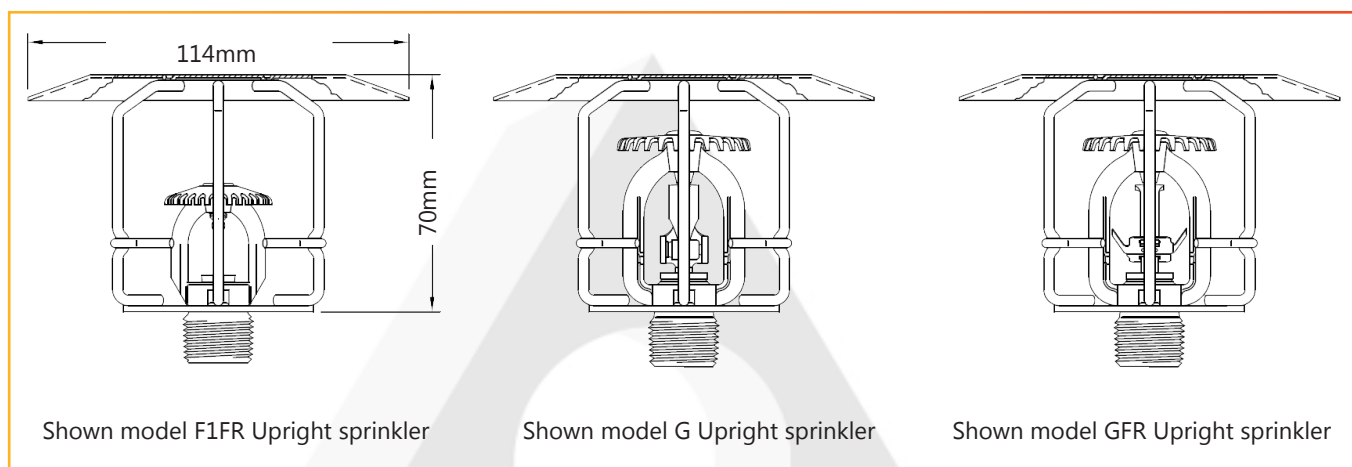

REF: SJR_082022_REV2

AQL PROTECCION

Carretera N-340 Km 1245, 3 Nave B-5 Polígono industrial El Pla 08750 Molins de Rei, Barcelona (España)
Tel. (+34) 936800376 * WhatsApp pedidos: 660781482 * www.aqlproteccion.com * aql@aqlproteccion.com

ANBER

Avda. de las Flores, 13-15 P.E. El Molino 28970 Humanes de Madrid, Madrid (España)
Tel. (+34) 916063711 * WhatsApp pedidos: 649787619 * www.anber.es * anber@anber.es

Model C-5 Guard/Shield Assembly

This assembly is a Model C-1 guard supplied with either an S-1 water shield threaded onto 1/2" sprinkler threads, or an S-2 water shield threaded onto 3/4" threads. The combination forms a pendent intermediate level sprinkler with guard.

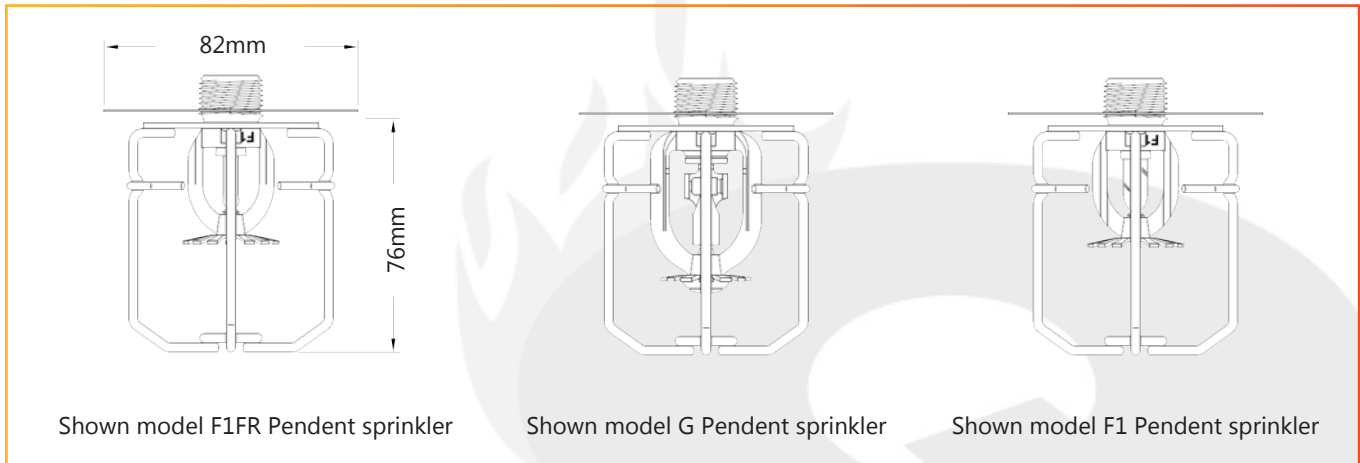

Model D Guards and Guard/Shield Assemblies

Model D-1 Guard

These guards are used with pendent, upright and horizontal sidewall sprinklers and do not incorporate a water shield.

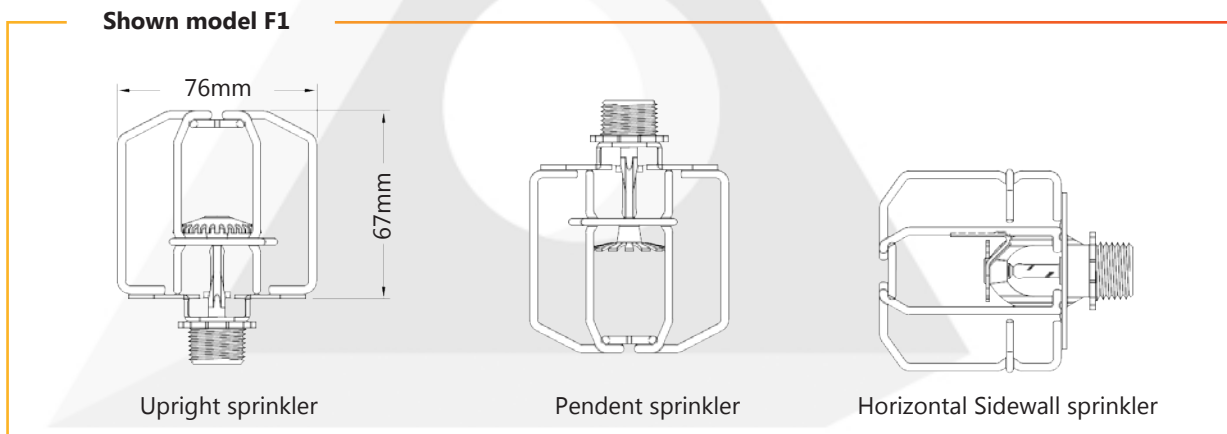
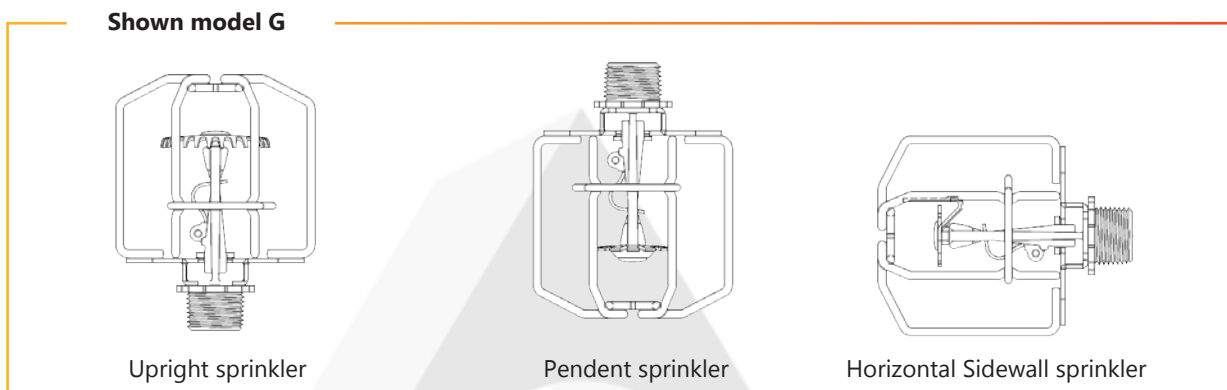

REF: SJR_082022_REV2

AQL PROTECCION

Carretera N-340 Km 1245, 3 Nave B-5 Polígono industrial El Pla 08750 Molins de Rei, Barcelona (España)
 Tel. (+34) 936800376 * WhatsApp pedidos: 660781482 * www.aqlproteccion.com * aql@aqlproteccion.com

ANBER

Avda. de las Flores, 13-15 P.E. El Molino 28970 Humanes de Madrid, Madrid (España)
 Tel. (+34) 916063711 * WhatsApp pedidos: 649787619 * www.anber.es * anber@anber.es

Model D-3, D-6, and D-7 Guards

These guards have a built-in water shield. When assembled to an upright sprinkler, the combination forms an upright intermediate sprinkler with guard.

Model D-3 Guards and Water Shield

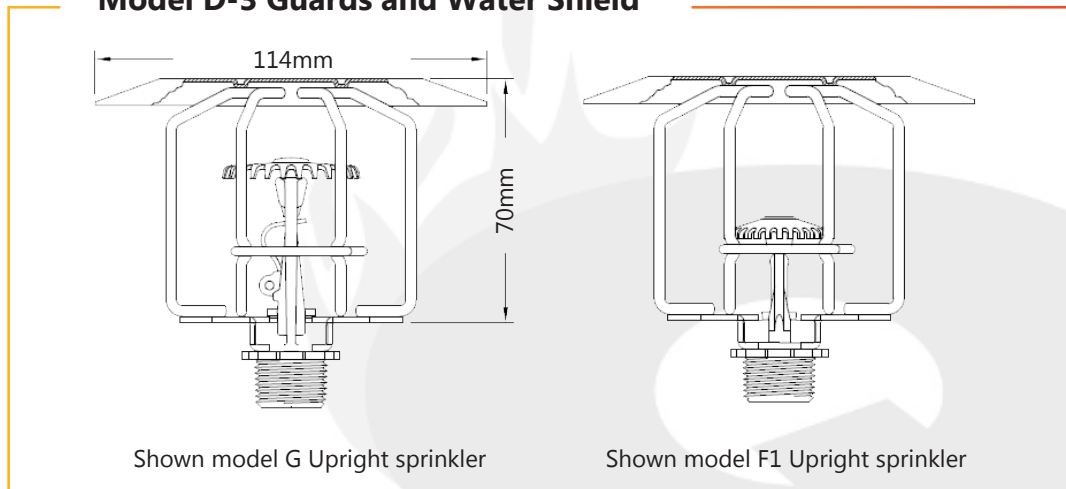

Model D-6 Guards and Water Shield

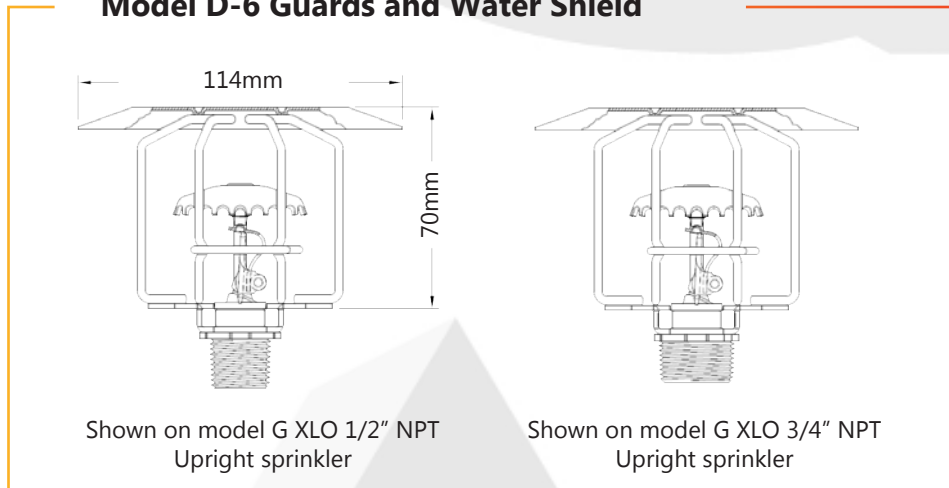

Model D-7 Guards and Water Shield



REF: SJR_082022_REV2

AQL PROTECCION

Carretera N-340 Km 1245, 3 Nave B-5 Polígono industrial El Pla 08750 Molins de Rei, Barcelona (España)
Tel. (+34) 936800376 * WhatsApp pedidos: 660781482 * www.aqlproteccion.com * aql@aqlproteccion.com

ANBER

Avda. de las Flores, 13-15 P.E. El Molino 28970 Humanes de Madrid, Madrid (España)
Tel. (+34) 916063711 * WhatsApp pedidos: 649787619 * www.anber.es * anber@anber.es

Model D-4 and D-5 Guard/Shield Assembly

These assemblies are model D-1 guards supplied with either an S-1 water shield threaded onto 1/2" sprinkler threads, or an S-2 water shield threaded onto 3/4" threads. The combination forms a pendent intermediate level sprinkler with guard.

Model D-4 Guards and Water Shield

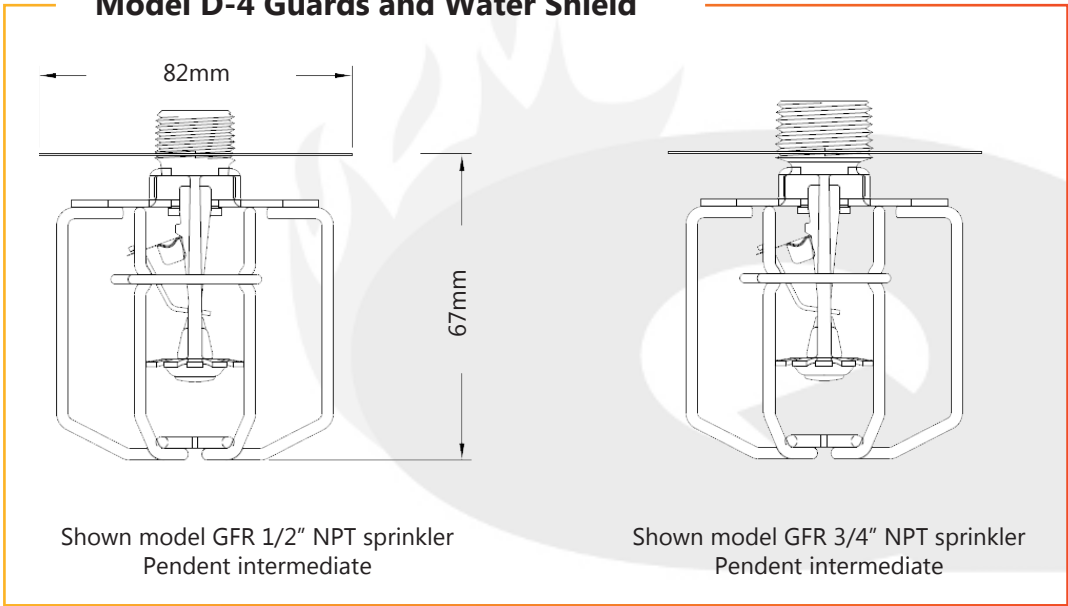

Model D-5 Guards and Water Shield

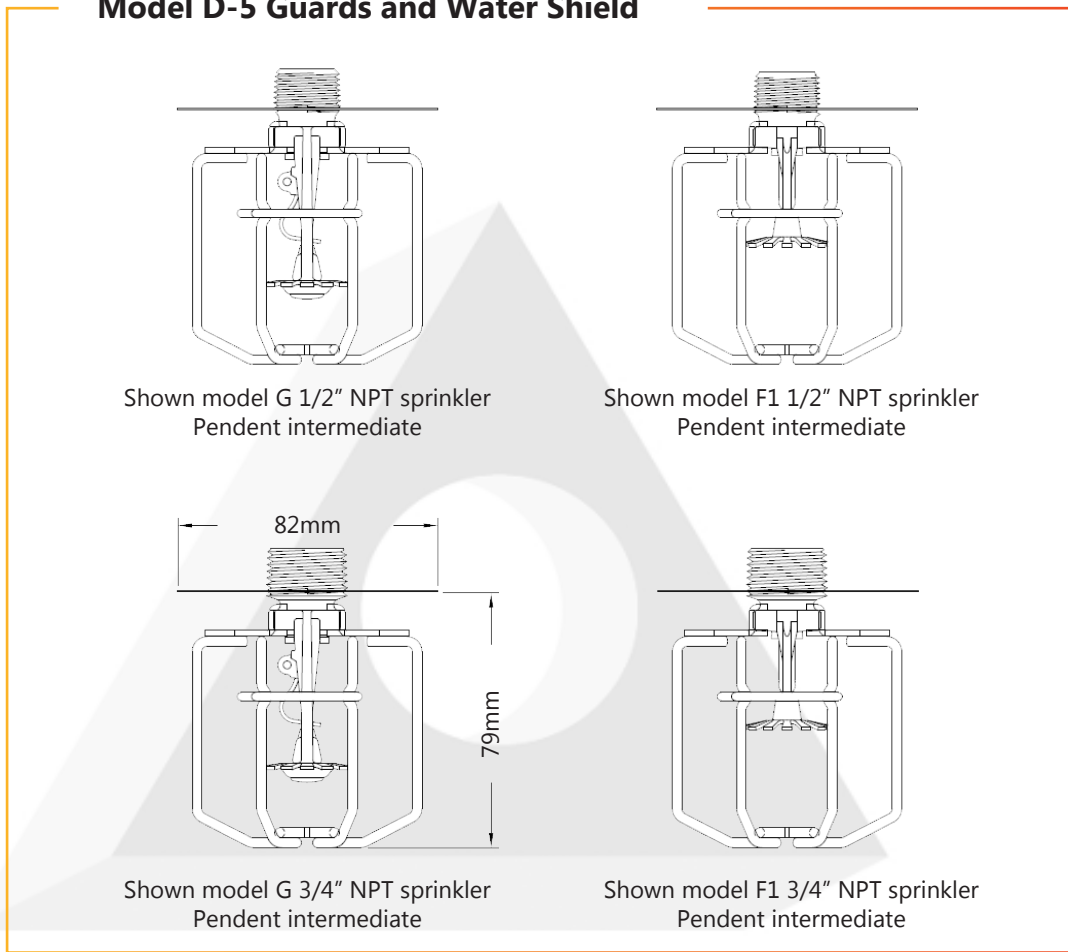

REF: SJR_082022_REV2

AQL PROTECCION

Carretera N-340 Km 1245, 3 Nave B-5 Polígono industrial El Pla 08750 Molins de Rei, Barcelona (España)
Tel. (+34) 936800376 * WhatsApp pedidos: 660781482 * www.aqlproteccion.com * aql@aqlproteccion.com

ANBER

Avda. de las Flores, 13-15 P.E. El Molino 28970 Humanes de Madrid, Madrid (España)
Tel. (+34) 916063711 * WhatsApp pedidos: 649787619 * www.anber.es * anber@anber.es

Model D-8 Guard

This guard is used with pendent and upright sprinklers and does not incorporate a water shield.

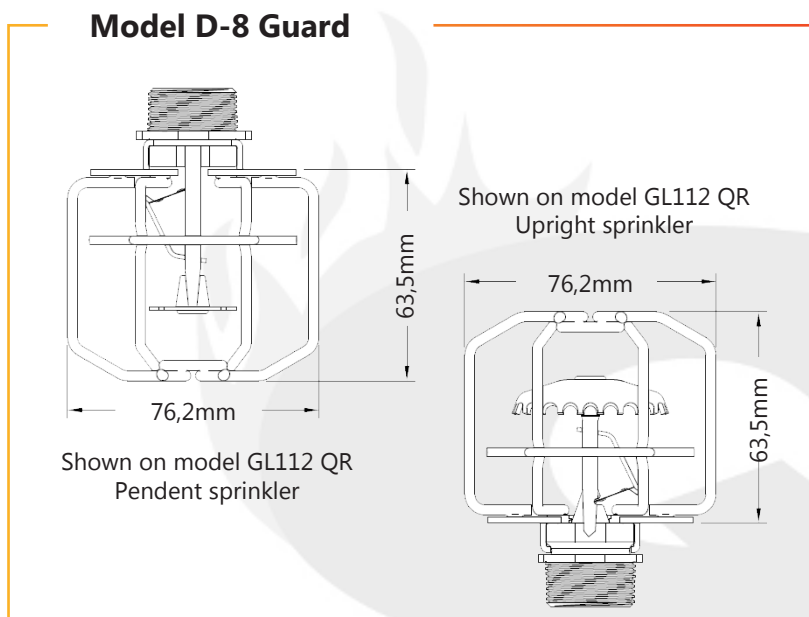

Model D-9 Guard/Shield Assembly

This assembly is a Model D-8 guard supplied with an S-2 water shield that is threaded onto 3/4" sprinkler threads. The combination forms a pendent intermediate level sprinkler with guard.

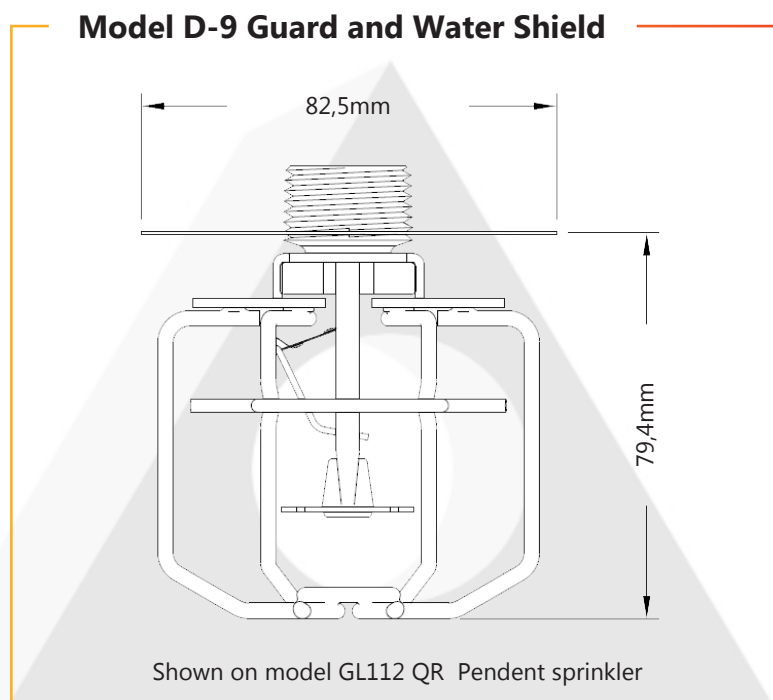

REF: SJR_082022_REV2

AQL PROTECCION

Carretera N-340 Km 1245, 3 Nave B-5 Polígono industrial El Pla 08750 Molins de Rei, Barcelona (España)
Tel. (+34) 936800376 * WhatsApp pedidos: 660781482 * www.aqlproteccion.com * aql@aqlproteccion.com

ANBER

Avda. de las Flores, 13-15 P.E. El Molino 28970 Humanes de Madrid, Madrid (España)
Tel. (+34) 916063711 * WhatsApp pedidos: 649787619 * www.anber.es * anber@anber.es

Model D-14 Guard

Model D-14 sprinkler guards are FM Approved for in-rack installation only. Each guard is supplied with a 1" locknut that must be threaded onto the sprinkler prior to sprinkler installation. Where permitted by Table A, the guards may also be used in combination with the S-5 water shield which replaces the locknut. The guard may be mounted to the sprinkler either prior to or following installation of the sprinkler into an outlet.

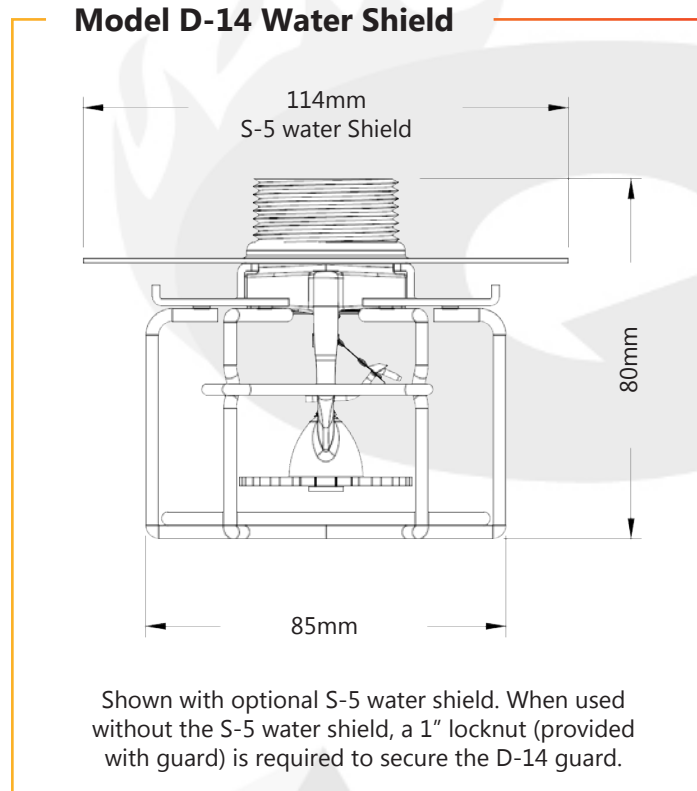

REF: SJR_082022_REV2

AQL PROTECCION

Carretera N-340 Km 1245, 3 Nave B-5 Polígono industrial El Pla 08750 Molins de Rei, Barcelona (España)
Tel. (+34) 936800376 * WhatsApp pedidos: 660781482 * www.aqlproteccion.com * aql@aqlproteccion.com

ANBER

Avda. de las Flores, 13-15 P.E. El Molino 28970 Humanes de Madrid, Madrid (España)
Tel. (+34) 916063711 * WhatsApp pedidos: 649787619 * www.anber.es * anber@anber.es

Model S Water Shields

Model S Shields are threaded water shields designed to create a pendent intermediate level sprinkler when installed on an approved sprinkler. The water shields are UL listed and/or FM Approved with the sprinklers listed in Table A, Listed and Approved Sprinkler, Guard and Water Shield Combinations.

Model S-1

Model S-1 (3 1/4" [83 mm] diameter) water shields are threaded onto 1/2" sprinkler inlet threads prior to installation.

Model S-2 and S-3

Model S-2 (3 1/4" [83 mm] diameter) and S-3 (3 3/4" [95 mm] diameter) water shields are threaded onto 3/4" sprinkler inlet threads prior to installation.

Model S-5

Model S-5 (4 1/2" [114 mm] diameter) water shields are threaded onto 1" sprinkler inlet threads prior to installation.

Note: Model S-3 water shields are intended and listed for use on Model JL14 and JL17 ESFR storage sprinklers.

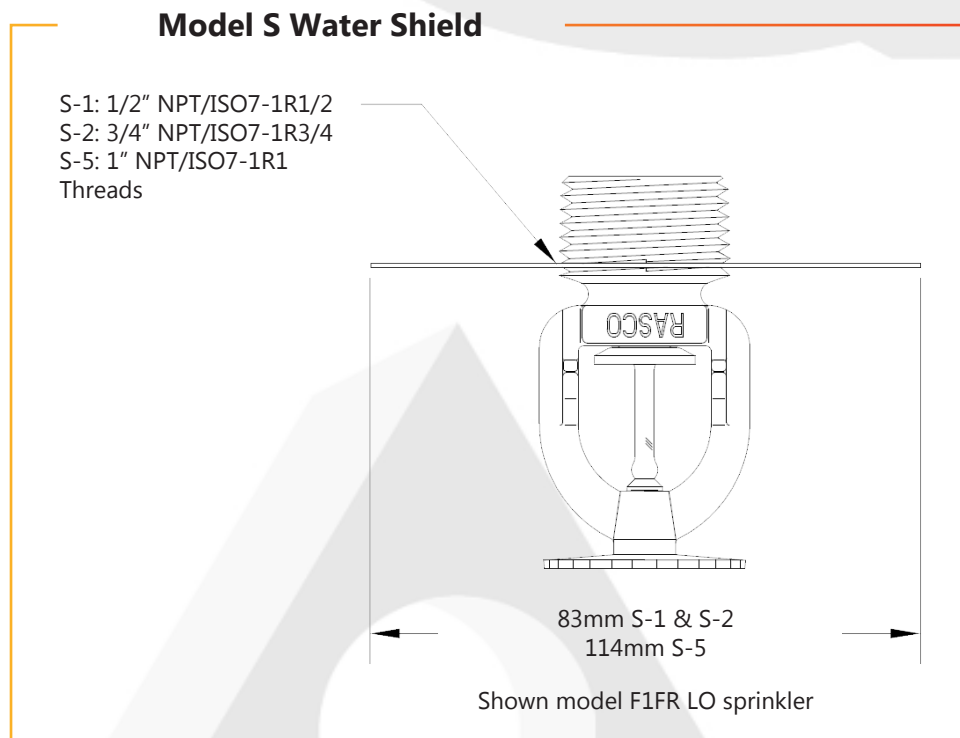

REF: SJR_082022_REV2

AQL PROTECCION

Carretera N-340 Km 1245, 3 Nave B-5 Polígono industrial El Pla 08750 Molins de Rei, Barcelona (España)
Tel. (+34) 936800376 * WhatsApp pedidos: 660781482 * www.aqlproteccion.com * aql@aqlproteccion.com

ANBER

Avda. de las Flores, 13-15 P.E. El Molino 28970 Humanes de Madrid, Madrid (España)
Tel. (+34) 916063711 * WhatsApp pedidos: 649787619 * www.anber.es * anber@anber.es

Model 22 and 25 Sprinkler Guards

Model 22 and 25 sprinkler guards are FM Approved for in-rack installation only. Each guard is supplied with a 1" locknut that must be threaded onto the sprinkler prior to sprinkler installation. Where permitted by Table A, the guards may also be used in combination with the S-5 water shield which replaces the locknut. The guard is assembled to the sprinkler following installation of the sprinkler.

Model 22 Guard

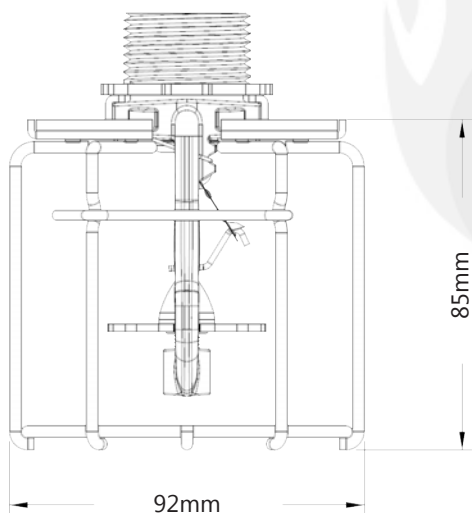

Model 25 Guard

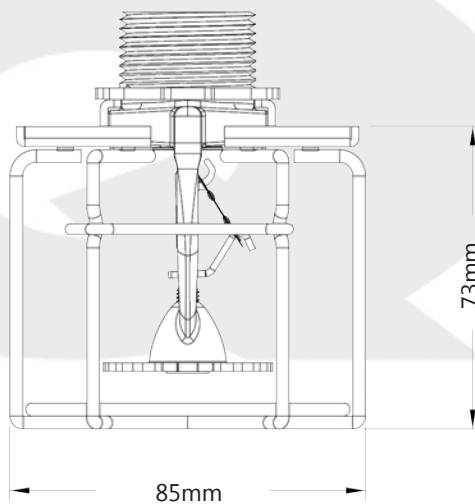

Model 22 Guard w/ S-5 Shield

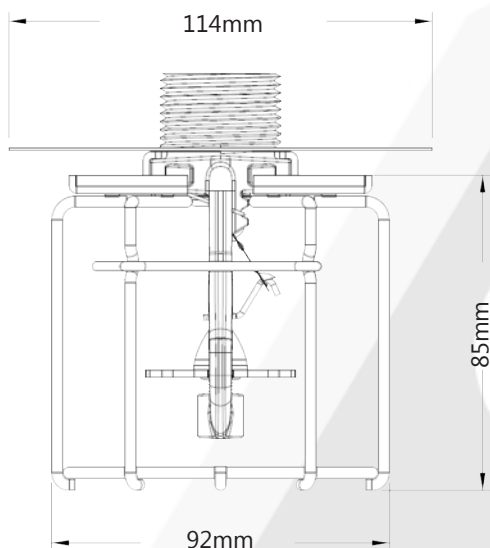

Model 25 Guard w/ S-5 Shield

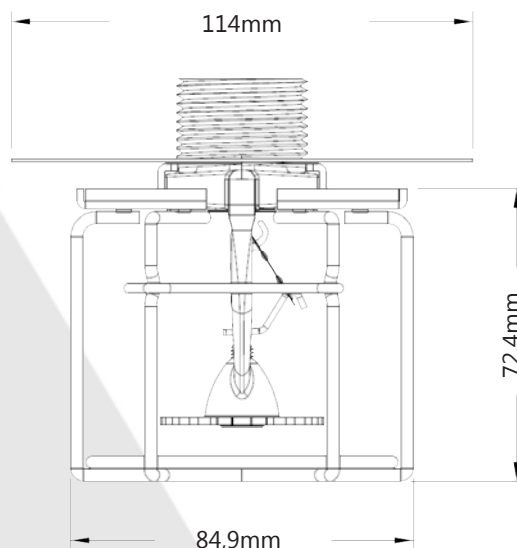

REF: SJR_082022_REV2

AQL PROTECCION

Carretera N-340 Km 1245, 3 Nave B-5 Polígono industrial El Pla 08750 Molins de Rei, Barcelona (España)
Tel. (+34) 936800376 * WhatsApp pedidos: 660781482 * www.aqlproteccion.com * aql@aqlproteccion.com

ANBER

Avda. de las Flores, 13-15 P.E. El Molino 28970 Humanes de Madrid, Madrid (España)
Tel. (+34) 916063711 * WhatsApp pedidos: 649787619 * www.anber.es * anber@anber.es

Model F Guards and Guards with Shields

The Model F guards and guards with shields are specifically designed for use with KFR sprinklers and various F1 and F1FR sprinklers being transitioned to KFR frames. These sprinklers are designated as "NEW" in Table A, "Listed and Approved Sprinkler, Guard and Water Shield Combinations."

Model F-1, F-2, F-4 and F-7

These guards are used with pendent, upright, horizontal sidewall and vertical sidewall sprinklers and do not incorporate a water shield.

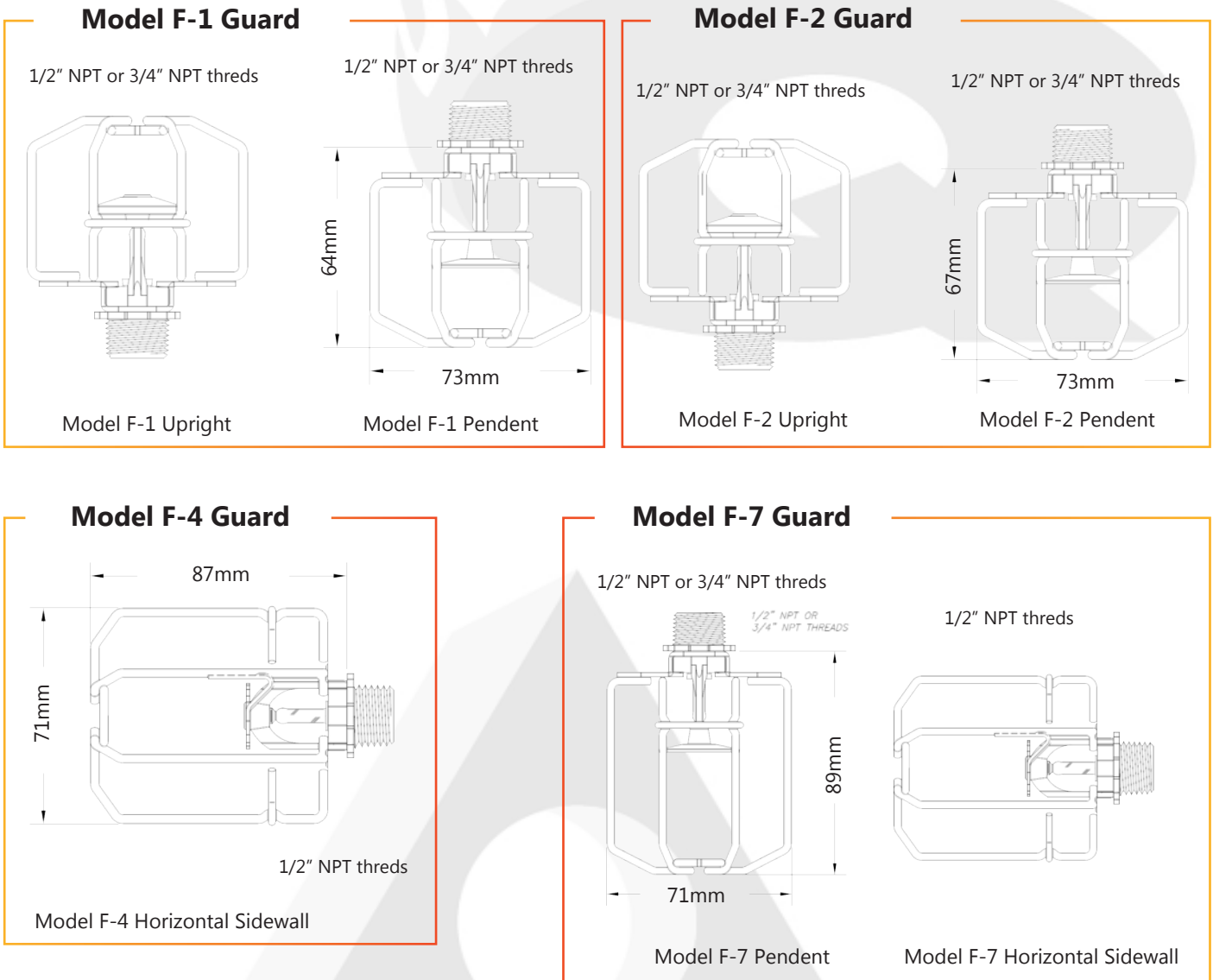

REF: SJR_082022_REV2

AQL PROTECCION

Carretera N-340 Km 1245, 3 Nave B-5 Polígono industrial El Pla 08750 Molins de Rei, Barcelona (España)
Tel. (+34) 936800376 * WhatsApp pedidos: 660781482 * www.aqlproteccion.com * aql@aqlproteccion.com

ANBER

Avda. de las Flores, 13-15 P.E. El Molino 28970 Humanes de Madrid, Madrid (España)
Tel. (+34) 916063711 * WhatsApp pedidos: 649787619 * www.anber.es * anber@anber.es

Model F-3 Guard

This guard has a built-in water shield. When assembled to an upright sprinkler, the combination forms an upright intermediate sprinkler with guard.

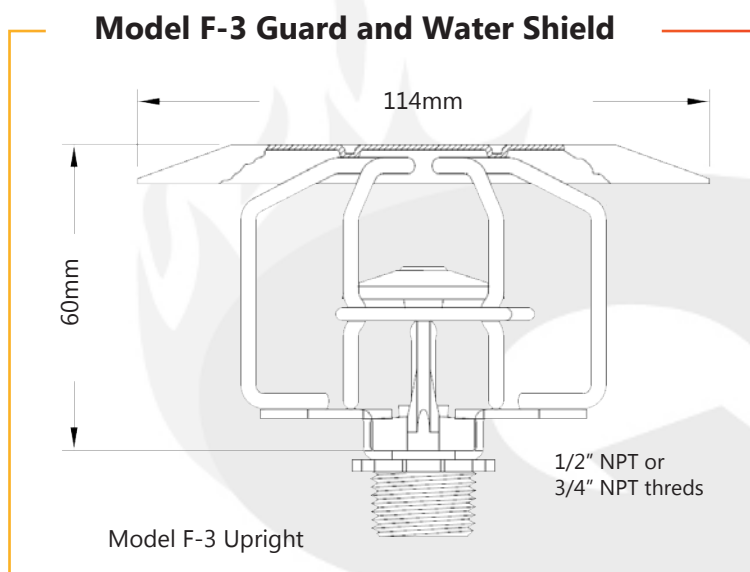

Model F-5 Guard/Shield Assembly

This assembly is a Model F-1 guard supplied with an S-1 water shield that is threaded onto 1/2" sprinkler threads. The combination forms a pendent intermediate level sprinkler with guard.

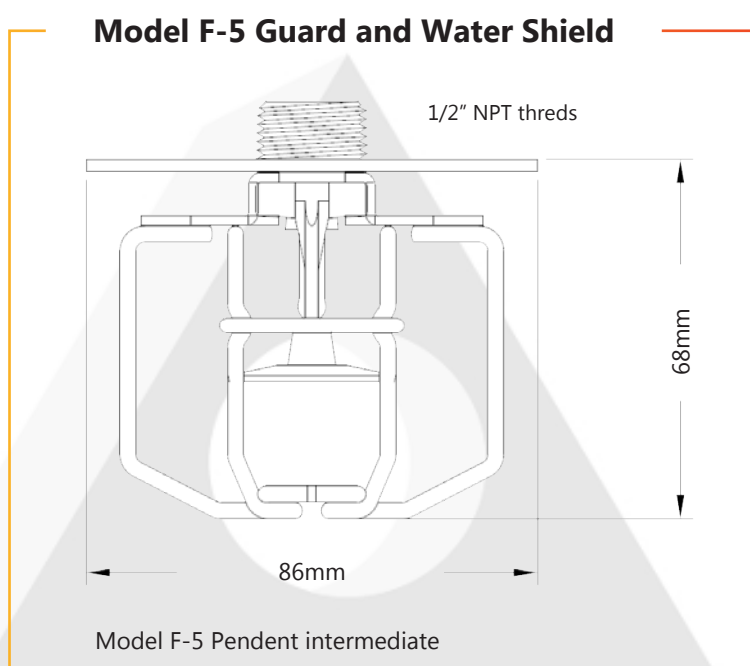

REF: SJR_082022_REV2

AQL PROTECCION

Carretera N-340 Km 1245, 3 Nave B-5 Polígono industrial El Pla 08750 Molins de Rei, Barcelona (España)
Tel. (+34) 936800376 * WhatsApp pedidos: 660781482 * www.aqlproteccion.com * aql@aqlproteccion.com

ANBER

Avda. de las Flores, 13-15 P.E. El Molino 28970 Humanes de Madrid, Madrid (España)
Tel. (+34) 916063711 * WhatsApp pedidos: 649787619 * www.anber.es * anber@anber.es

Model F-6 Guard/Shield Assembly

This assembly is a Model F-2 guard supplied with an S-2 water shield that is threaded onto 3/4" sprinkler threads. The combination forms a pendent intermediate level sprinkler with guard.

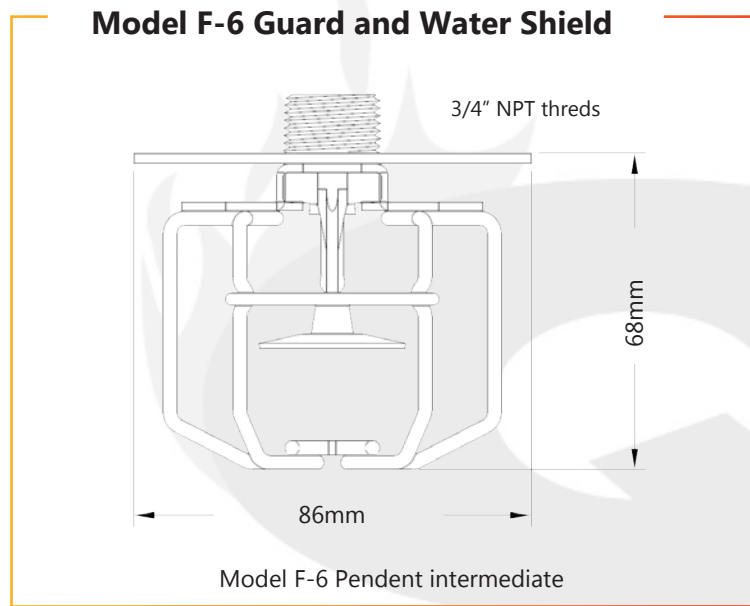

Model F-8 Guard/Shield Assembly

This assembly is a model F-7 guard supplied with either an S-1 water shield which is threaded onto 1/2" sprinkler threads, or an S-2 water shield threaded onto 3/4" threads. The combination forms a pendent intermediate level sprinkler with guard.

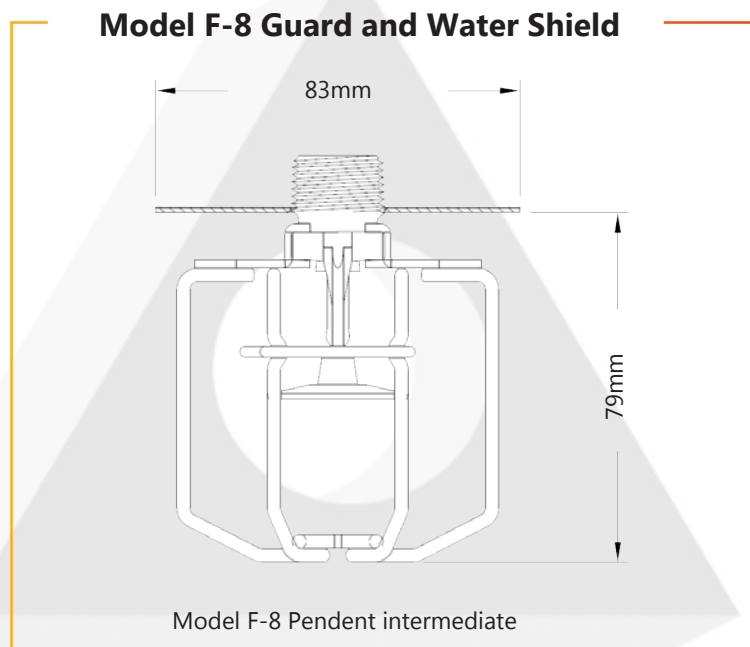

REF: SJR_082022_REV2

AQL PROTECCION

Carretera N-340 Km 1245, 3 Nave B-5 Polígono industrial El Pla 08750 Molins de Rei, Barcelona (España)
Tel. (+34) 936800376 * WhatsApp pedidos: 660781482 * www.aqlproteccion.com * aql@aqlproteccion.com

ANBER

Avda. de las Flores, 13-15 P.E. El Molino 28970 Humanes de Madrid, Madrid (España)
Tel. (+34) 916063711 * WhatsApp pedidos: 649787619 * www.anber.es * anber@anber.es

TABLE A: Listed and Approved Sprinkler, Guard, and Water Shield Combinations

| Sprinkler Model ⁽¹⁾ | Type ⁽²⁾ | Sprinkler Identification Number (SIN) | Nominal K-Factor gpm/psi ^{1/2} (L/min/bar ^{1/2}) | Sensitivity ⁽³⁾ | Threads NPT or ISO7-1 | Sprinkler and Guard or Water Shield Approvals ⁽⁴⁾ | Guard or Water Shield Model |
|--------------------------------|---------------------|---------------------------------------|---|----------------------------|-----------------------|--|--|
| F1LO | Pendent | R1712 | 8.0 (115) | SR | 3/4 | cULus | D-1 Guard D-5 Guard and Shield S-2 Shield |
| | | | | | | FM | C-1 Guard C-5 Guard and Shield S-2 Shield |
| | Upright | R1722 | 8.0 (115) | SR | 3/4 | cULus | D-1 Guard C-3 Guard and Shield D-3 Guard and Shield |
| F1LO-300 | Pendent | RA5512 | 8.0 (115) | SR | 3/4 | cULus | D-1 Guard D-5 Guard and Shield S-2 Shield |
| | Upright | RA5522 | 8.0 (115) | SR | 3/4 | cULus | D-1 Guard C-3 Guard and Shield D-3 Guard and Shield |
| F1-28 | Pendent | RA1311 | 2.8 (40) | SR | 1/2 | cULus | D-1 Guard |
| | Upright | RA1321 | 2.8 (40) | SR | 1/2 | cULus | D-1 Guard |
| F1-28 NEW ⁽⁸⁾ | Pendent | RA1311 | 2.8 (40) | SR | 1/2 | cULus | F-7 Guard F-8 Guard and Shield S-1 Shield |
| | Upright | RA1321 | 2.8 (40) | SR | 1/2 | cULus | F-1 Guard F-3 Guard and Shield |
| F1-42 | Pendent | RA1313 | 4.2 (60) | SR | 1/2 | cULus | D-1 Guard |
| | Upright | RA1323 | 4.2 (60) | SR | 1/2 | cULus | D-1 Guard |
| F1-42 NEW ⁽⁸⁾ | Pendent | RA1313 | 4.2 (60) | SR | 1/2 | cULus | F-7 Guard F-8 Guard and Shield S-1 Shield |
| | Upright | RA1323 | 4.2 (60) | SR | 1/2 | cULus | F-1 Guard F-3 Guard and Shield |
| F1-56 | HSW | RA1335 | 5.6 (80) | SR | 1/2 | cULus | D-1 Guard |
| | | | | | | FM | C-1 Guard |
| | Pendent | RA1314 | 5.6 (80) | SR | 1/2 | cULus | D-1 Guard D-5 Guard and Shield S-1 Shield |
| | | | | | | FM | C-1 Guard C-5 Guard and Shield D-1 Guard D-4 Guard and Shield D-5 Guard and Shield S-1 Shield |
| | Upright | RA1325 | 5.6 (80) | SR | 1/2 | cULus | D-1 Guard C-3 Guard and Shield D-3 Guard and Shield |
| | | | | | | FM | C-1 Guard C-3 Guard and Shield |
| VSW | RA1385 | 5.6 (80) | SR | 1/2 | FM | C-1 Guard | |
| F1-56 NEW ⁽⁸⁾ | HSW | RA1335 | 5.6 (80) | SR | 1/2 | cULus | F-7 Guard |
| | | | | | | FM | F-4 Guard |
| | Pendent | RA1314 | 5.6 (80) | SR | 1/2 | cULus | F-7 Guard F-8 Guard and Shield S-1 Shield |
| | | | | | | FM | F-1 Guard F-5 Guard and Shield S-1 Shield |
| | Upright | RA1325 | 5.6 (80) | SR | 1/2 | cULus | F-1 Guard F-3 Guard and Shield |
| | | | | | | FM | F-1 Guard F-3 Guard and Shield |
| VSW | RA1385 | 5.6 (80) | SR | 1/2 | cULus | NA | |
| | | | | | FM | F-2 Guard | |

Notes on page 18.

REF: SJR_082022_REV2

AQL PROTECCION

Carretera N-340 Km 1245, 3 Nave B-5 Polígono industrial El Pla 08750 Molins de Rei, Barcelona (España)
Tel. (+34) 936800376 * WhatsApp pedidos: 660781482 * www.aqlproteccion.com * aql@aqlproteccion.com

ANBER

Avda. de las Flores, 13-15 P.E. El Molino 28970 Humanes de Madrid, Madrid (España)
Tel. (+34) 916063711 * WhatsApp pedidos: 649787619 * www.anber.es * anber@anber.es

TABLE A: Listed and Approved Sprinkler, Guard, and Water Shield Combinations

| Sprinkler Model ⁽¹⁾ | Type ⁽²⁾ | Sprinkler Identification Number (SIN) | Nominal K-Factor gpm/psi ^{1/2} (L/min/bar ^{1/2}) | Sensitivity ⁽³⁾ | Threads NPT or ISO7-1 | Sprinkler and Guard or Water Shield Approvals ⁽⁴⁾ | Guard or Water Shield Model |
|--------------------------------|---------------------|---------------------------------------|---|----------------------------|-----------------------|--|--|
| F1-56-300 | Pendent | RA2514 | 5.6(80) | SR | 1/2 | cULus | D-1 Guard D-5 Guard and Shield S-1 Shield |
| | Upright | RA2525 | 5.6(80) | SR | 1/2 | cULus | D-1 Guard C-3 Guard and Shield D-3 Guard and Shield |
| F1-56-300 NEW ⁽⁸⁾ | Pendent | RA2514 | 5.6(80) | SR | 1/2 | cULus | F-7 Guard F-8 Guard and Shield S-1 Shield |
| | Upright | RA2525 | 5.6(80) | SR | 1/2 | cULus | F-1 Guard F-3 Guard and Shield |
| F1-56SS | Pendent | RA6414 | 5.6(80) | SR | 1/2 | cULus | D-1 Guard D-5 Guard and Shield S-1 Shield |
| | | | | | | FM | C-1 Guard C-5 Guard and Shield D-1 Guard D-4 Guard and Shield D-5 Guard and Shield S-1 Shield |
| | Upright | RA6424 | 5.6(80) | SR | 1/2 | cULus | D-1 Guard C-3 Guard and Shield D-3 Guard and Shield |
| | | | | | | FM | C-1 Guard C-3 Guard and Shield |
| F1-80 NEW ⁽⁸⁾ | Pendent | RA6212 | 8.0(115) | SR | 3/4 | cULus | F-7 Guard F-8 Guard and Shield S-2 Shield |
| | | | | | | FM | F-2 Guard F-6 Guard and Shield S-2 Shield |
| | Upright | RA6222 | 8.0(115) | SR | 3/4 | cULus | F-1 Guard F-3 Guard and Shield |
| | | | | | | FM | F-2 Guard F-3 Guard and Shield |
| F1-80SS | Pendent | RA6412 | 8.0(115) | SR | 3/4 | cULus | D-1 Guard D-5 Guard and Shield S-2 Shield |
| | | | | | | FM | C-1 Guard C-5 Guard and Shield S-2 Shield |
| F1-80SS | Upright | RA6422 | 8.0(115) | SR | 3/4 | cULus | D-1 Guard C-3 Guard and Shield D-3 Guard and Shield |
| | | | | | | | |
| F1FRLO | Pendent | R3612 | 8.0(115) | QR | 3/4 | cULus | D-1 Guard D-5 Guard and Shield S-2 Shield |
| | | | | | | FM | C-1 Guard C-5 Guard and Shield S-2 Shield |
| | Upright | R3622 | 8.0(115) | QR | 3/4 | cULus | D-1 Guard D-3 Guard and Shield C-3 Guard and Shield |
| | | | | | | FM | C-1 Guard C-3 Guard and Shield |

Notes on page 18.

REF: SJR_082022_REV2

AQL PROTECCION

Carretera N-340 Km 1245, 3 Nave B-5 Polígono industrial El Pla 08750 Molins de Rei, Barcelona (España)
Tel. (+34) 936800376 * WhatsApp pedidos: 660781482 * www.aqlproteccion.com * aql@aqlproteccion.com

ANBER

Avda. de las Flores, 13-15 P.E. El Molino 28970 Humanes de Madrid, Madrid (España)
Tel. (+34) 916063711 * WhatsApp pedidos: 649787619 * www.anber.es * anber@anber.es

TABLE A: Listed and Approved Sprinkler, Guard, and Water Shield Combinations

| Sprinkler Model ⁽¹⁾ | Type ⁽²⁾ | Sprinkler Identification Number (SIN) | Nominal K-Factor gpm/psi ^{1/2} (L/min/bar ^{1/2}) | Sensitivity ⁽³⁾ | Threads NPT or ISO7-1 | Sprinkler and Guard or Water Shield Approvals ⁽⁴⁾ | Guard or Water Shield Model |
|--------------------------------|---------------------|---------------------------------------|---|----------------------------|-----------------------|--|--|
| F1FR28 | Pendent | RA1411 | 2.8 (40) | QR | 1/2 | cULus | D-1 Guard |
| | Upright | RA1421 | 2.8 (40) | QR | 1/2 | cULus | D-1 Guard |
| F1FR28 NEW ⁽⁸⁾ | Pendent | RA1411 | 2.8 (40) | QR | 1/2 | cULus | F-7 Guard F-8 Guard and Shield S-1 Shield |
| | Upright | RA1421 | 2.8 (40) | QR | 1/2 | cULus | F-1 Guard F-3 Guard and Shield |
| F1FR-300 | Pendent | R5612 | 8.0 (115) | QR | 3/4 | cULus | D-1 Guard D-5 Guard and Shield S-2 Shield |
| | Upright | R5622 | 8.0 (115) | QR | 3/4 | cULus | D-1 Guard |
| F1FR42 | Pendent | RA1413 | 4.2 (60) | QR | 1/2 | cULus | D-1 Guard |
| | Upright | RA1423 | 4.2 (60) | QR | 1/2 | cULus | D-1 Guard |
| F1FR42 NEW ⁽⁸⁾ | Pendent | RA1413 | 4.2 (60) | QR | 1/2 | cULus | F-7 Guard F-8 Guard and Shield S-1 Shield |
| | Upright | RA1423 | 4.2 (60) | QR | 1/2 | cULus | F-1 Guard F-3 Guard and Shield |
| F1FR56 | HSW | RA1435 | 5.6 (80) | QR | 1/2 | cULus | D-1 Guard |
| | | | | | | FM | C-1 Guard |
| | Pendent | RA1414 | 5.6 (80) | QR | 1/2 | cULus | D-1 Guard D-5 Guard and Shield S-1 Shield |
| | | | | | | FM | C-1 Guard C-5 Guard and Shield D-1 Guard D-4 Guard and Shield D-5 Guard and Shield S-1 Shield |
| | Upright | RA1425 | 5.6 (80) | QR | 1/2 | cULus | D-1 Guard C-3 Guard and Shield D-3 Guard and Shield |
| | | | | | | FM | C-1 Guard C-3 Guard and Shield |
| VSW | RA1485 | 5.6 (80) | QR | 1/2 | FM | C-1 Guard | |
| F1FR56 NEW ⁽⁸⁾ | HSW | RA1435 | 5.6 (80) | QR | 1/2 | cULus | F-7 Guard |
| | | | | | | FM | F-4 Guard |
| | Pendent | RA1414 | 5.6 (80) | QR | 1/2 | cULus | F-7 Guard F-8 Guard and Shield S-1 Shield |
| | | | | | | FM | F-1 Guard F-5 Guard and Shield S-1 Shield |
| | Upright | RA1425 | 5.6 (80) | QR | 1/2 | cULus | F-1 Guard F-3 Guard and Shield |
| | | | | | | FM | F-1 Guard F-3 Guard and Shield |
| VSW | RA1485 | 5.6 (80) | QR | 1/2 | cULus | NA | |
| | | | | | | FM | F-2 Guard |

Notes on page 18.

REF: SJR_082022_REV2

TABLE A: Listed and Approved Sprinkler, Guard, and Water Shield Combinations

| Sprinkler Model ⁽¹⁾ | Type ⁽²⁾ | Sprinkler Identification Number (SIN) | Nominal K-Factor gpm/psi ^{1/2} (L/min/bar ^{1/2}) | Sensitivity ⁽³⁾ | Threads NPT or ISO7-1 | Sprinkler and Guard or Water Shield Approvals ⁽⁴⁾ | Guard or Water Shield Model |
|--------------------------------|---------------------|---------------------------------------|---|----------------------------|-----------------------|--|--|
| F1FR56-300 | HSW | RA2634 | 5.6 (80) | QR | 1/2 | cULus | D-1 Guard |
| | Pendent | RA2614 | 5.6 (80) | QR | 1/2 | FM | D-1 Guard D-5 Guard and Shield S-1 Shield |
| | Upright | RA2625 | 5.6 (80) | QR | 1/2 | cULus | D-1 Guard C-3 Guard and Shield D-3 Guard and Shield |
| F1FR56-300 NEW ⁽⁸⁾ | HSW | RA2634 | 5.6 (80) | QR | 1/2 | cULus | F-7 Guard |
| | Pendent | RA2614 | 5.6 (80) | QR | 1/2 | cULus | F-7 Guard F-8 Guard and Shield S-1 Shield |
| | Upright | RA2625 | 5.6 (80) | QR | 1/2 | cULus | F-1 Guard F-3 Guard and Shield |
| F1FR56SS | Pendent | RA6514 | 5.6 (80) | QR | 1/2 | cULus | D-1 Guard D-5 Guard and Shield |
| | | | | | | FM | C-1 Guard C-5 Guard and Shield D-1 Guard D-4 Guard and Shield D-5 Guard and Shield |
| | Upright | RA6524 | 5.6 (80) | QR | 1/2 | cULus | D-1 Guard C-3 Guard and Shield D-3 Guard and Shield |
| | | | | | | FM | C-1 Guard C-3 Guard and Shield |
| F1FR80 NEW ⁽⁸⁾ | Pendent | RA6312 | 8.0 (115) | QR | 3/4 | cULus | F-7 Guard F-8 Guard and Shield S-2 Shield |
| | | | | | | FM | F-2 Guard F-6 Guard and Shield S-2 Shield |
| | Upright | RA6322 | 8.0 (115) | QR | 3/4 | cULus | F-1 Guard F-3 Guard and Shield |
| | | | | | | FM | F-2 Guard F-3 Guard and Shield |
| FUTURE | | | | | | | |
| F1FR80SS | Pendent | RA6412 | 8.0 (115) | QR | 3/4 | cULus | D-1 Guard D-5 Guard and Shield S-2 Shield |
| | | | | | | FM | C-1 Guard C-5 Guard and Shield S-2 Shield |
| | Upright | RA6522 | 8.0 (115) | QR | 3/4 | cULus | C-1 Guard C-3 Guard and Shield |
| F3-56 Dry | Pendent | R5314 | 5.6 (80) | SR | 1 | cULus, FM | C-2 Guard ⁽⁵⁾ |
| | HSW | R5334 | 5.6 (80) | SR | 1 | FM | C-2 Guard ⁽⁵⁾ |
| F3QR56 Dry | Pendent | R5714 | 5.6 (80) | QR | 1 | cULus, FM | C-2 Guard ⁽⁵⁾ |
| | HSW | R5734 | 5.6 (80) | QR | 1 | FM | C-2 Guard ⁽⁵⁾ |

Notes on page 18.

REF: SJR_082022_REV2

AQL PROTECCION

Carretera N-340 Km 1245, 3 Nave B-5 Polígono industrial El Pla 08750 Molins de Rei, Barcelona (España)
Tel. (+34) 936800376 * WhatsApp pedidos: 660781482 * www.aqlproteccion.com * aql@aqlproteccion.com

ANBER

Avda. de las Flores, 13-15 P.E. El Molino 28970 Humanes de Madrid, Madrid (España)
Tel. (+34) 916063711 * WhatsApp pedidos: 649787619 * www.anber.es * anber@anber.es

TABLE A: Listed and Approved Sprinkler, Guard, and Water Shield Combinations

| Sprinkler Model ⁽¹⁾ | Type ⁽²⁾ | Sprinkler Identification Number (SIN) | Nominal K-Factor gpm/psi ^{1/2} (L/min/bar ^{1/2}) | Sensitivity ⁽³⁾ | Threads NPT or ISO7-1 | Sprinkler and Guard or Water Shield Approvals ⁽⁴⁾ | Guard or Water Shield Model | |
|--------------------------------|---------------------|---------------------------------------|---|----------------------------|-----------------------|--|---|------------------------|
| FUTURE | | | | | | | | |
| G | HSW | R1231 | 2.8 (40) | SR | 1/2 | cULus | D-1 Guard | |
| | | R1233 | 4.2 (60) | SR | 1/2 | cULus | D-1 Guard | |
| | | R1235 | 5.6 (80) | SR | 1/2 | cULus FM | D-1 Guard C-1 Guard | |
| | | R1236 | 8.0 (115) | SR | 1/2 | cULus | D-1 Guard | |
| | | R1237 | 8.0 (115) | SR | 3/4 | cULus | D-1 Guard | |
| | Pendent | R1011 | 2.8 (40) | SR | 1/2 | cULus FM | D-1 Guard C-1 Guard | |
| | | R1013 | 4.2 (60) | SR | 1/2 | cULus | D-1 Guard | |
| | | R1015 | 5.6 (80) | SR | 1/2 | cULus | D-1 Guard D-5 Guard and Shield S-1 Shield | |
| | | | | | | FM | C-1 Guard C-5 Guard and Shield S-1 Shield | |
| | | R1016 | 8.0 (115) | SR | 1/2 | cULus | D-1 Guard D-5 Guard and Shield | |
| | | | | | | FM | C-1 Guard | |
| | | R1017 | 8.0 (115) | SR | 3/4 | cULus | D-1 Guard D-5 Guard and Shield S-2 Shield | |
| | | | | | | FM | C-1 Guard C-5 Guard and Shield S-2 Shield | |
| | | Upright | R1021 | 2.8 (40) | SR | 1/2 | cULus FM | D-1 Guard C-1 Guard |
| | | | R1023 | 4.2 (60) | SR | 1/2 | cULus | D-1 Guard |
| | R1025 | | 5.6 (80) | SR | 1/2 | cULus | D-1 Guard C-3 Guard and Shield D-3 Guard and Shield | |
| | | | | | | FM | C-1 Guard C-3 Guard and Shield | |
| | R1026 | | 8.0 (115) | SR | 1/2 | cULus | D-1 Guard C-3 Guard and Shield D-3 Guard and Shield | |
| | | | | | | FM | C-1 Guard C-3 Guard and Shield | |
| | R1027 | | 8.0 (115) | SR | 3/4 | cULus | D-1 Guard C-3 Guard and Shield D-3 Guard and Shield | |
| | | | | | | FM | C-1 Guard C-3 Guard and Shield | |
| | VSW | R1285 | 5.6 (80) | SR | 1/2 | FM | C-1 Guard | |

Notes on page 18.

REF: SJR_082022_REV2

AQL PROTECCION

Carretera N-340 Km 1245, 3 Nave B-5 Polígono industrial El Pla 08750 Molins de Rei, Barcelona (España)
Tel. (+34) 936800376 * WhatsApp pedidos: 660781482 * www.aqlproteccion.com * aql@aqlproteccion.com

ANBER

Avda. de las Flores, 13-15 P.E. El Molino 28970 Humanes de Madrid, Madrid (España)
Tel. (+34) 916063711 * WhatsApp pedidos: 649787619 * www.anber.es * anber@anber.es

TABLE A: Listed and Approved Sprinkler, Guard, and Water Shield Combinations

| Sprinkler Model ⁽¹⁾ | Type ⁽²⁾ | Sprinkler Identification Number (SIN) | Nominal K-Factor gpm/psi ^{1/2} (L/min/bar ^{1/2}) | Sensitivity ⁽³⁾ | Threads NPT or ISO7-1 | Sprinkler and Guard or Water Shield Approvals ⁽⁴⁾ | Guard or Water Shield Model |
|--------------------------------|---------------------|---------------------------------------|---|----------------------------|-----------------------|--|---|
| FURURE | | | | | | | |
| GFR | HSW | R3131 | 2.8 (40) | QR | 1/2 | cULus | D-1 Guard |
| | | R3133 | 4.2 (60) | QR | 1/2 | cULus | D-1 Guard |
| | | R3135 | 5.6 (80) | QR | 1/2 | cULus | D-1 Guard |
| | | R3137 | 8.0 (115) | QR | 3/4 | cULus | D-1 Guard |
| | Pendent | R3111 | 2.8 (40) | QR | 1/2 | cULus | D-1 Guard |
| | | R3113 | 4.2 (60) | QR | 1/2 | cULus | D-1 Guard |
| | | R3115 | 5.6 (80) | QR | 1/2 | cULus | D-1 Guard D-4 Guard and Shield S-1 Shield |
| | | R3117 | 8.0 (115) | QR | 3/4 | cULus FM | D-1 Guard D-4 Guard and Shield S-2 Shield C-5 Guard and Shield |
| | Upright | R3121 | 2.8 (40) | QR | 1/2 | cULus | D-1 Guard |
| | | R3123 | 4.2 (60) | QR | 1/2 | cULus | D-1 Guard |
| | | R3125 | 5.6 (80) | QR | 1/2 | cULus | D-1 Guard C-3 Guard and Shield D-3 Guard and Shield |
| | | R3127 | 8.0 (115) | QR | 3/4 | cULus FM | D-1 Guard C-3 Guard and Shield D-3 Guard and Shield C-3 Guard and Shield |
| GL112 | Pendent | R3216 | 11.2 (160) | QR | 3/4 | FM | D-8 Guard D-9 Guard and Shield S-2 Shield |
| | Upright | R3226 | 11.2 (160) | QR | 3/4 | FM | D-7 Guard and Shield D-8 Guard |
| GXLO | Pendent | R2916 | 11.2 (160) | SR | 3/4 | FM | D-8 Guard D-9 Guard and Shield S-2 Shield |
| | Upright | R2921 | 11.2 (160) | SR | 3/4 | cULus FM | D-6 Guard and Shield D-7 Guard and Shield D-8 Guard |
| HL22 Threaded | Pendent | RA1011 | 22.4 (320) | ESFR | 1 | FM | 22 Guard ⁽⁶⁾ S-5 Shield ⁽⁶⁾⁽⁷⁾ |
| JL14 | Pendent | RA1812 | 14.0 (200) | ESFR | 3/4 | FM | S-3 Shield |
| JL17 | Pendent | RA1914 | 16.8 (240) | ESFR | 3/4 | FM | S-3 Shield |
| KFR56 | Pendent | RA3614 | 5.6 (80) | QR | 1/2 | cULus | F-7 Guard F-8 Guard and Shield S-1 Shield |
| | | | | | | FM | F-1 Guard F-5 Guard and Shield S-1 Shield |
| | Upright | RA3624 | 5.6 (80) | QR | 1/2 | cULus | F-1 Guard F-3 Guard and Shield |
| | | | | | | FM | F-1 Guard F-3 Guard and Shield |
| HSW | RA3634 | 5.6 (80) | QR | 1/2 | cULus | F-7 Guard | |
| | | | | | FM | F-4 Guard | |

Notes on page 18.

REF: SJR_082022_REV2

AQL PROTECCION

Carretera N-340 Km 1245, 3 Nave B-5 Polígono industrial El Pla 08750 Molins de Rei, Barcelona (España)
Tel. (+34) 936800376 * WhatsApp pedidos: 660781482 * www.aqlproteccion.com * aql@aqlproteccion.com

ANBER

Avda. de las Flores, 13-15 P.E. El Molino 28970 Humanes de Madrid, Madrid (España)
Tel. (+34) 916063711 * WhatsApp pedidos: 649787619 * www.anber.es * anber@anber.es

TABLE A: Listed and Approved Sprinkler, Guard, and Water Shield Combinations

| Sprinkler Model ⁽¹⁾ | Type ⁽²⁾ | Sprinkler Identification Number (SIN) | Nominal K-Factor gpm/psi ^{1/2} (L/min/bar ^{1/2}) | Sensitivity ⁽³⁾ | Threads NPT or ISO7-1 | Sprinkler and Guard or Water Shield Approvals ⁽⁴⁾ | Guard or Water Shield Model |
|--------------------------------|---------------------|---------------------------------------|---|----------------------------|-----------------------|--|---|
| FURURE | | | | | | | |
| KFR56-300 | Pendent | RA3914 | 5.6 (80) | QR | 1/2 | cULus | F-7 Guard F-8 Guard /Water Shield S-1 Water Shield |
| | Upright | RA3924 | | | | | F-1 Guard F-3 Guard/Water Shield |
| | HSW | RA3934 | | | | | F-7 Guard |
| KFR80 | Pendent | RA5412 | 8.0 (115) | QR | 3/4 | cULus | F-7 Guard F-8 Guard and Shield S-2 Shield |
| | | | | | | FM | F-2 Guard F-6 Guard and Shield S-2 Shield |
| | Upright | RA5422 | | | | cULus | F-1 Guard F-3 Guard and Shield |
| | | | | | | FM | F-2 Guard F-3 Guard and Shield |
| N25 Threaded | Pendent | RA0912 | 25.2 (360) | ESFR | 1 | FM | 25 Guard ⁽⁶⁾ S-5 Shield ⁽⁶⁾⁽⁷⁾ |
| N252EC | Pendent | RA0842 | 25.2 (360) | QR | 1 | FM | 25 Guard ⁽⁶⁾ |
| P22 Threaded | Pendent | R601 | 22.4 (320) | ESFR | 1 | FM | D-14 Guard ⁽⁶⁾ S-5 Shield ⁽⁶⁾⁽⁷⁾ |
| P25 Threaded | Pendent | R602 | 25.2(360) | ESFR | 1 | FM | D-14 Guard ⁽⁶⁾ S-5 Shield ⁽⁶⁾⁽⁷⁾ |

Notes:

- (1) Sprinkler guards and water shields are listed and approved only for use with specific sprinklers. The use of any other guards or water shields on these sprinklers may impede their operation or distribution and negate all approvals and warranties.
- (2) HSW: Horizontal Sidewall; VSW: Vertical Sidewall.
- (3) QR: Quick-response; SR: Standard-response; ESFR: Early Suppression Fast Response.
- (4) In addition, SSL Approval for C-1, C-2 and C-3 guards and water shields.
- (5) Model C-2 guards are listed and work only with standard and HB type escutcheons. Model C-2 guards cannot be used with FP or F1 recessed escutcheons.
- (6) FM Approved for intermediate-level use only, such as in-rack, under conveyors, mezzanines, or other similar obstructions. Only for use with threaded sprinklers.
- (7) When used in combination with a guard, the S-5 Shield replaces the 1" lock washer provided with the guard.
- (8) Sprinklers designated as "NEW" are updated versions of legacy sprinklers and MUST use F-series guards and guards with shields. These sprinklers will be designated with the suffix "N" on orders.

REF: SJR_082022_REV2

Refer to Table A. Listed and Approved Sprinkler, Guard and Water Shield Combinations for information on Listings and Approvals applicable to each guard and water shield.

1. Listed by Underwriters Laboratories, Inc. and UL certified for Canada (cULus).
2. Certified by FM Approvals.
3. Scientific Services Laboratories (SSL, Australia)*.

* For Models C1, C2, C3 guards.

INSTALLATION

Model C-1, C-2 & C-3 Guards

Install the sprinkler in accordance with the applicable sprinkler installation instructions prior to installing the Model C guard. With both clips unhooked, slightly spread open the guard. Insert steel plate into the installed sprinkler between the threads and the wrench flats. The steel plate tabs should face the sprinkler wrench flats and four contact points engage the sprinkler neck.

For Model C-2, the steel plate fits into the groove in each wrench flat and the guard is located by the notch in both steel plates. Snap the upper locking clip into place, then close the near clip. The guard is now securely installed in place. If locking clip requires too much force to snap closed or open, slightly flex the wires on both sides of the clip and either close or open the clip.

Model C-5 Guard/Shield Assembly

Prior to installing sprinkler into fitting, thread the Model S-1 (1/2") or S-2 (3/4") water shield onto the sprinkler. After installing sprinkler into fitting, install the Model C-1 Guard per the instructions above.

Model D Guards

Model D series guards and water shields are designed to be installed on the sprinkler prior to sprinkler installation. Assemble the guard on the sprinkler using the following technique:

With both cups unhooked, slightly spread open the guard. Insert steel plate into the installed sprinkler between the threads and the wrench flats. The steel plate tabs should face the sprinkler wrench flats and four contact points should engage the sprinkler neck.

Snap the upper locking clip (steel plates) into place. Close the lower clip at the top of the guard and slide it down to the notch. After installing the guard, thread EITHER a 1/2" or 3/4" lock nut (for guard only) OR an S-1 (1/2") or S-2 (3/4") water shield (for guard/shield assembly) onto the sprinkler threads. The final assembly can then be installed into a fitting using only the wrench indicated in Table B "Wrench for Installation of Guard, Water Shield, and Sprinkler Assembly." The guard is more securely installed. Install the lock nut on to the NPT threads until the nut is securely against the guard.

REF: SJR_082022_REV2

AQL PROTECCION

Carretera N-340 Km 1245, 3 Nave B-5 Polígono industrial El Pla 08750 Molins de Rei, Barcelona (España)
Tel. (+34) 936800376 * WhatsApp pedidos: 660781482 * www.aqlproteccion.com * aql@aqlproteccion.com

ANBER

Avda. de las Flores, 13-15 P.E. El Molino 28970 Humanes de Madrid, Madrid (España)
Tel. (+34) 916063711 * WhatsApp pedidos: 649787619 * www.anber.es * anber@anber.es

Model F Guards

Model F series guards and guards with shields are designed to be installed on the sprinkler prior to installation. The assembly is then installed with the wrench indicated in Table B, Wrench for Installation of Guard, Water Shield, and Sprinkler Assembly.

Models F-1, F-2, F-3, F-4 & F-7

Assemble the guard on the sprinklers using the technique described for the Model D-1, then install a 1/2" or 3/4" locking nut on the NPT threads until the nut is tight against the guard.

Models F-5, F-6, & F-8

Assemble the guard on the sprinklers using the technique described for the Model D-1, then install a 1/2" or 3/4" threaded water shield on the NPT threads until the shield is tight against the guard.

Model 22 & 25 Guards

Install the provided locknut on the sprinkler threads prior to installation of the sprinkler. Install the sprinkler in accordance with the applicable sprinkler installation instructions. With both clips unhooked, slightly spread open the guard. Insert the guard over the installed sprinkler so that the base plate of the guard attaches to the wrench flats of the sprinkler. Connect both locking clips to the adjacent tines of the guard. Tighten the locknut against the base plate of the guard.

Model S Water Shields

Model S water shields are designed to be installed on the sprinkler prior to installation. Thread the Model S water shield onto the sprinkler by hand, making sure that the shield does not pass by the end of the threads near the wrench boss. Install the sprinkler/shield assembly with the wrench indicated in the appropriate Technical Bulletin for the sprinkler.

Installation Notes:

1. For all products incorporating a lock-nut feature, the lock-nut is part of the listed assembly. Failure to install the lock-nut will void the listing of the product and may lower the impact tolerance of the device.
2. The products in this bulletin are NOT compatible with recessed or concealed sprinkler installations.

REF: SJR_082022_REV2

AQL PROTECCION

Carretera N-340 Km 1245, 3 Nave B-5 Polígono industrial El Pla 08750 Molins de Rei, Barcelona (España)
Tel. (+34) 936800376 * WhatsApp pedidos: 660781482 * www.aqlproteccion.com * aql@aqlproteccion.com

ANBER

Avda. de las Flores, 13-15 P.E. El Molino 28970 Humanes de Madrid, Madrid (España)
Tel. (+34) 916063711 * WhatsApp pedidos: 649787619 * www.anber.es * anber@anber.es

TABLE B: Wrench for Installation of Guard, Water Shield and Sprinkler Assembly

| Guard / Water Shield | Required Wrench for Installation of Guard, Water Shield, and Sprinkler Assembly | Guard / Water Shield | Required Wrench for Installation of Guard, Water Shield, and Sprinkler Assembly |
|----------------------|---|----------------------|---|
| D-1 | Model JD K5.6 and smaller sprinklers Model J K8.0 sprinklers | D-6 | Model JV |
| D-3 | | D-7 | |
| D-4 | | D-8 | |
| D-5 | | D-9 | |
| F (all) | Model J | D-14 | Model W16 |

TABLE C: Guard Finishes

| Standard | Special application |
|---------------------------------|---|
| Zinc plated with clear chromate | Enamel red paint, Custom color paint, Bright Chrome and Dull Chrome |

TABLE D: Water Shield Finishes - S Series Water Shields

| Standard | Special application |
|------------|---|
| Galvanized | Enamel red paint and Custom color paint |

ORDERING INFORMATION

Specify:

- Guard, Guard with Shield or Shield Model.
- Sprinkler Thread Size (required for Model D-4 and D-5 only).
- Finish (see tables C and D).
- Wrench (see table B).

Note: Factory installation of Models D and F guards is available at additional cost. Please contact your Reliable representative for details.

REF: SJR_082022_REV2

AQL PROTECCION

Carretera N-340 Km 1245, 3 Nave B-5 Polígono industrial El Pla 08750 Molins de Rei, Barcelona (España)
Tel. (+34) 936800376 * WhatsApp pedidos: 660781482 * www.aqlproteccion.com * aql@aqlproteccion.com

ANBER

Avda. de las Flores, 13-15 P.E. El Molino 28970 Humanes de Madrid, Madrid (España)
Tel. (+34) 916063711 * WhatsApp pedidos: 649787619 * www.anber.es * anber@anber.es